

INSTRUCTION BOOK

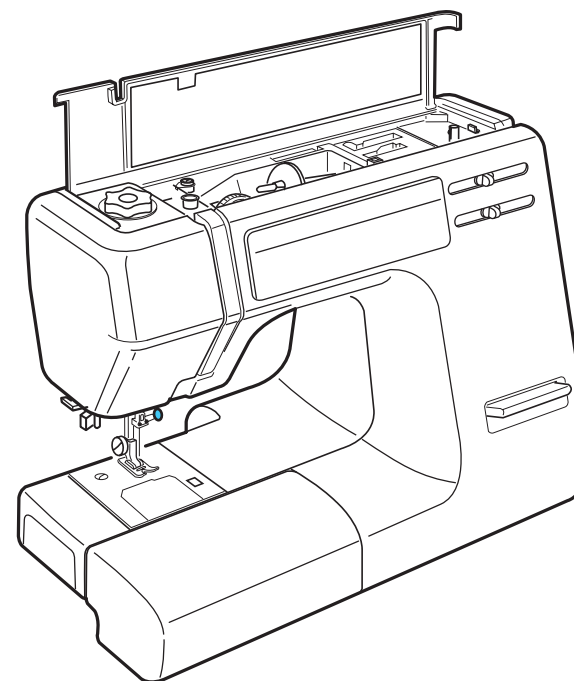

IMPORTANT SAFETY INSTRUCTIONS

When using an electrical appliance, basic safety precautions should always be followed, including the following:

This sewing machine is designed and manufactured for household use only.

Read all instructions before using this sewing machine.

DANGER — To reduce the risk of electric shock:

1. An appliance should never be left unattended when plugged in. Always unplug this sewing machine from the electric outlet immediately after using and before cleaning.

WARNING — To reduce the risk of burns, fire, electric shock, or injury to persons:

1. Do not allow to be used as a toy. Close attention is necessary when this sewing machine is used by or near children.
2. Use this appliance only for its intended use as described in this owner's manual. Use only attachments recommended by the manufacturer as contained in this owner's manual.
3. Never operate this sewing machine if it has a damaged cord or plug, if it is not working properly, if it has been dropped or damaged, or dropped into water. Return this sewing machine to the nearest authorized dealer or service center for examination, repair, electrical or mechanical adjustment.
4. Never operate the appliance with any air opening blocked. Keep ventilation openings of this sewing machine and foot controller free from accumulation of lint, dust and loose cloth.
5. Never drop or insert any object into any opening.
6. Do not use outdoors.
7. Do not operate where aerosol (spray) products are being used or where oxygen is being administered.
8. To disconnect, turn all controls to the off ("O") position, then remove plug from outlet.
9. Do not unplug by pulling on cord. To unplug, grasp the plug, not the cord.
10. Keep fingers away from all moving parts. Special care is required around the sewing machine needle and/or cutting blade.
11. Always use the proper needle plate. The wrong plate can cause the needle to break.
12. Do not use bent needles.
13. Do not pull or push fabric while stitching. It may deflect the needle causing it to break.
14. Switch this sewing machine off ("O") when making any adjustment in the needle area, such as threading the needle, changing the needle, threading the bobbin or changing the presser foot, and the like.
15. Always unplug this sewing machine from the electrical outlet when removing covers, lubricating, or when making any other adjustments mentioned in this owner's manual.

SAVE THESE INSTRUCTIONS

For Europe only:

This appliance can be used by children aged from 8 years and above and persons with reduced physical, sensory or mental capabilities or lack of experience and knowledge if they have been given supervision or instruction concerning use of the appliance in a safe way and understand the hazards involved. Children shall not play with the appliance. Cleaning and user maintenance shall not be made by children without supervision.

For outside Europe (except U.S.A and Canada):

This appliance is not intended for use by persons (including children) with reduced physical, sensory or mental capabilities, or lack of experience and knowledge, unless they have been given supervision or instruction concerning use of the appliance by a person responsible for their safety. Children should be supervised to ensure that they do not play with the appliance.



Please note that on disposal, this product must be safely recycled in accordance with relevant National legislation relating to electrical/electronic products. If in doubt please contact your retailer for guidance. (European Union only)

Table of Contents

Names of Parts	2	Corded Buttonhole	26
Detachable Extension Table	3	Zipper Sewing	27–28
Accessory Storage Compartment	4	• To Snap On the Zipper Foot	27
Connecting Machine to Power Supply	5	• Fabric Preparation	27
Foot Control	5	• To Sew	27–28
Pressure Dial	6	Rolled Hem	29
To Raise or Drop the Feed Dog	6	Blind Stitch Hemming	30
To Remove and Attach Presser Foot	7	Decorative Satin Stitch Patterns	31
To Remove and Attach the Foot Holder	7	Stretch Stitch Patterns	31
Reverse Button	7	Adjusting Stretch Stitch Balance	32
Presser Foot Lifter	7	Smocking	32
Changing Needle	8	Quilting	33
Changing, Thread and Needle Chart	8	Pin Tucking	33
Winding the Bobbin	9	Shell Tuck	34
• Set the Spool	9	Fagoting	34
• Removing the Bobbin	9	Appliqué	35
• Winding the Bobbin	10	Patch Work	35
• Inserting the Bobbin	11	Scallop Hems	36
Threading the Machine	12	Elastic Stitch	36
• Needle Threader	13	Care of Your Machine	37
• Drawing Up the Bobbin Thread	14	• Cleaning the Hook Race and	
Adjust the Top Thread Tension	15	Feed Dog	37
• Choose the Correct Tension	15	• Replacing the Bobbin Holder	37
• Tension is too tight	15	Troubleshooting	38–39
• Tension is too loose	15		
Pattern Selector Dial	16		
Zigzag Width Control	16		
Stitch Length Control	16		
Infinite Needle Position	16		
Straight Stitching	17		
• Starting to Sew	17		
• Changing Sewing Direction	17		
• Finishing Sewing	17		
Sewing on Heavy Fabrics	18		
Seam Allowance Lines	18		
Turn a Square Corner	18		
Zigzag Stitching	19		
Overcasting	19		
Overedge Stitch	20		
Tricot Stitch	20		
Triple Strength Stitch	21		
Outline Stretch Stitch	21		
Sewing Buttons	22		
Automatic Buttonhole	23–25		
• To Alter the Stitch Density	25		

Names of Parts

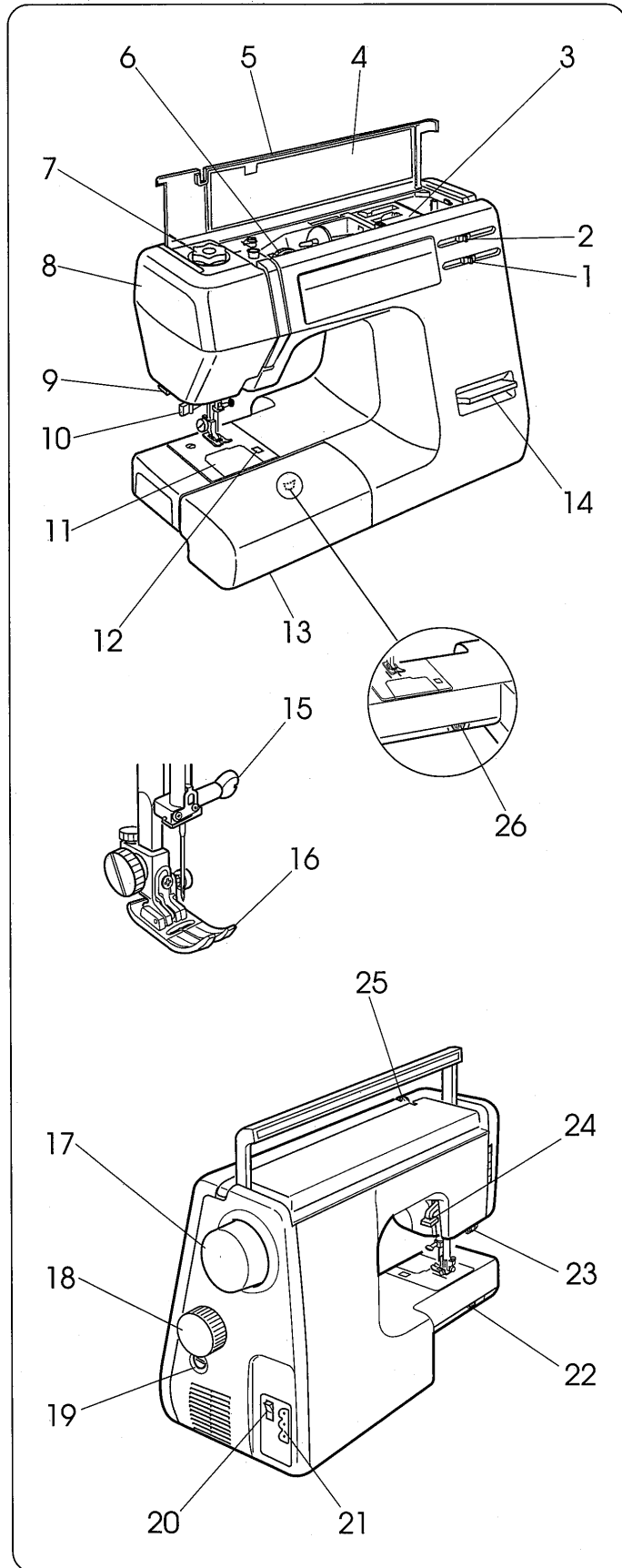

1. Stitch length control
2. Zigzag width control
3. Foot storage compartment
4. Flip-top sewing instruction panel
5. Top cover
6. Thread tension dial
7. Pressure dial
8. Face plate
9. Thread cutter
10. Needle threader
11. Hook cover plate
12. Hook cover plate release button
13. Extension table (Accessory storage box)
14. Reverse button
15. Needle clamp screw
16. Presser foot
17. Handwheel
18. Pattern selector dial
19. Feed balance dial
20. Power switch
21. Machine socket
22. Drop feed lever
23. Buttonhole lever
24. Presser foot lifter
25. Thread take-up lever
26. BH pitch balance adjusting dial

Troubleshooting, cont'd

Condition	Cause	Reference
Gathering	1. The needle thread tension is too loose. 2. The needle is too heavy or light for the fabrics being sewn.	Refer to page 15 Refer to page 8
The machine doesn't work.	1. The machine is not plugged in. 2. A thread is caught in the hook race. 3. The bobbin winder spindle is still in the winding position.	Refer to page 5 Refer to page 37 Refer to page 10
Patterns are distorted.	1. The stitch is not balanced.	Refer to page 32
The automatic buttonhole stitches are not working.	1. The stitch density is not suitable for the fabric being sewn. 2. Interfacing is not being used with stretch fabrics.	Refer to page 25 Refer to page 23
Noisy operation.	1. There is thread caught in the hook race. 2. Lint has built up in the bobbin holder or hook race.	Refer to page 37 Refer to page 37

Troubleshooting

Condition	Cause	Reference
The needle thread breaks.	<ol style="list-style-type: none"> 1. The needle thread is not threaded properly. 2. The needle thread tension is too tight. 3. The needle is bent or blunt. 4. The needle is incorrectly inserted. 5. The needle thread and the bobbin thread are not set properly under (drawn to the rear of) the presser foot when sewing is starting. 6. The fabric is not drawn to the rear when sewing is finished. 7. The thread is too heavy or too fine for the needle. 	<p>Refer to page 12 Refer to page 15 Refer to page 8 Refer to page 8 Refer to page 17</p> <p>Refer to page 17 Refer to page 8</p>
The bobbin thread breaks.	<ol style="list-style-type: none"> 1. The bobbin thread is not threaded properly in the bobbin holder. 2. Lint has collected in the bobbin holder. 3. The bobbin is damaged and doesn't turn smoothly. 	<p>Refer to page 11</p> <p>Refer to page 37 Change the bobbin</p>
The needle breaks.	<ol style="list-style-type: none"> 1. The needle is incorrectly inserted. 2. The needle is bent or blunt. 3. The needle clamp screw is loose. 4. The needle thread tension is too tight. 5. The fabric is not drawn to the rear when sewing is finished. 6. The needle is too fine for the fabric being sewn. 7. The pattern selector dial has been turned while the needle was in the material. 	<p>Refer to page 8 Refer to page 8 Refer to page 8 Refer to page 15 Refer to page 17 Refer to page 8 Refer to page 16</p>
Skipped stitches.	<ol style="list-style-type: none"> 1. The needle is incorrectly inserted. 2. The needle is bent or blunt. 3. The needle and/or threads are not suitable for the work being sewn. 4. A blue tipped needle is not being used for sewing stretch, very fine fabrics or synthetics. 5. The needle thread is not threaded properly. 6. The presser foot pressure is not strong enough. 7. The wrong needle is used. 	<p>Refer to page 8 Refer to page 8 Refer to page 8</p> <p>Refer to page 8</p> <p>Refer to page 12 Refer to page 6 Change the needle</p>
Seam puckering.	<ol style="list-style-type: none"> 1. The needle thread tension is not tight. 2. The needle thread is not threaded properly. 3. The needle is too heavy for the fabric being sewn. 4. The stitch length is too long for the fabric. 5. The presser foot pressure is not correctly adjusted. 	<p>Refer to page 15 Refer to page 12 Refer to page 8 Make stitch denser Refer to page 6</p>
The cloth is not feeding smoothly.	<ol style="list-style-type: none"> 1. The feed dog is packed with lint. 2. The presser foot pressure is too weak. 3. The stitches are too fine. 4. The feed dog was not raised after being lowered. 	<p>Refer to page 37 Refer to page 6 Make stitch coarser Refer to page 6</p>

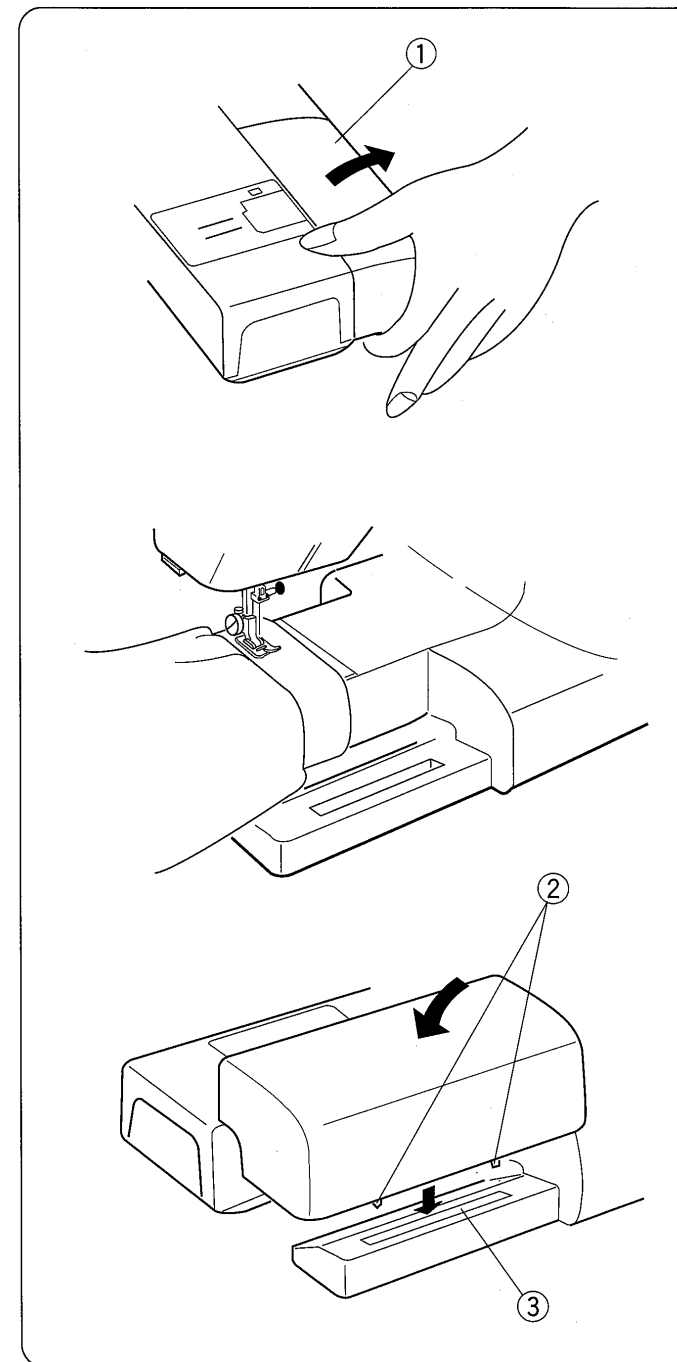

Detachable Extension Table

For Free Arm Sewing

To remove, lift out the extension table toward you as illustrated.

Advantages of free arm sewing:

- * Avoid fabric bunching around the needle when bar tacking to reinforce pockets, plackets and waistlines.
- * For stitching sleeves, waistbands, pants legs, or any circular garment area.
- * For darning socks or mending knees, elbows, or areas of wear in children's clothes.

For Flat-bed Sewing

Position the tabs on the base grooves and push down gently.

- ① Extension table
- ② Tabs
- ③ Base grooves

Accessory Storage Compartment

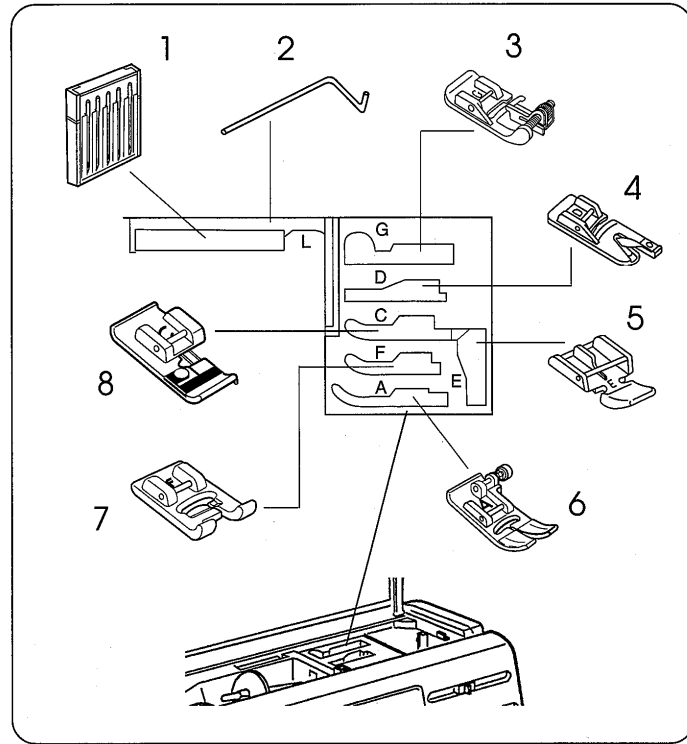

1. Set of needles
2. L: Quilter
3. G: Blind stitch hem foot
4. D: Hemmer foot
5. E: Zipper foot
6. A: Zigzag foot
7. F: Satin stitch foot
8. C: Overedge foot

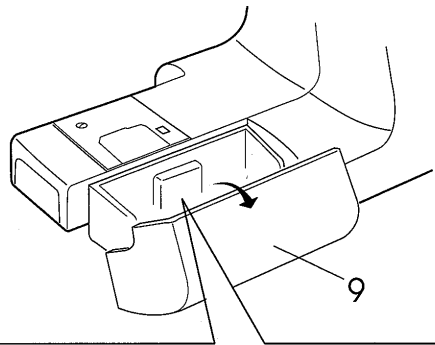

9. Extension table
Open the extension table toward you for a convenient place to store your accessories.

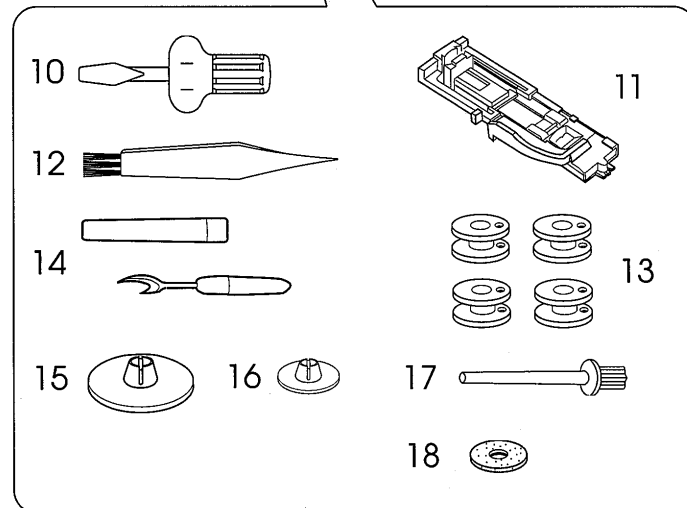

10. Screwdriver
11. R: Automatic buttonhole foot
12. Lint brush
13. Bobbin
14. Seam ripper
15. Large spool holder
16. Small spool holder
17. Additional spool pin
18. Spool pin felt

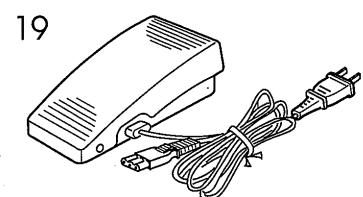

Other

19. Foot control

Care of Your Machine

Caution:

Before performing any of the following, make sure that the sewing machine is unplugged from the power source.

- * Turn the handwheel toward you to raise the needle and unplug the machine before cleaning.
- * Do not dismantle the machine other than explained on this page.
- * The machine never needs oiling.
- * Do not store the machine in a high-humidity area, near a heat radiator or in direct sunlight.
- * Clean the outside of the machine with a soft cloth and neutral soap.

Cleaning the Hook Race and Feed Dog

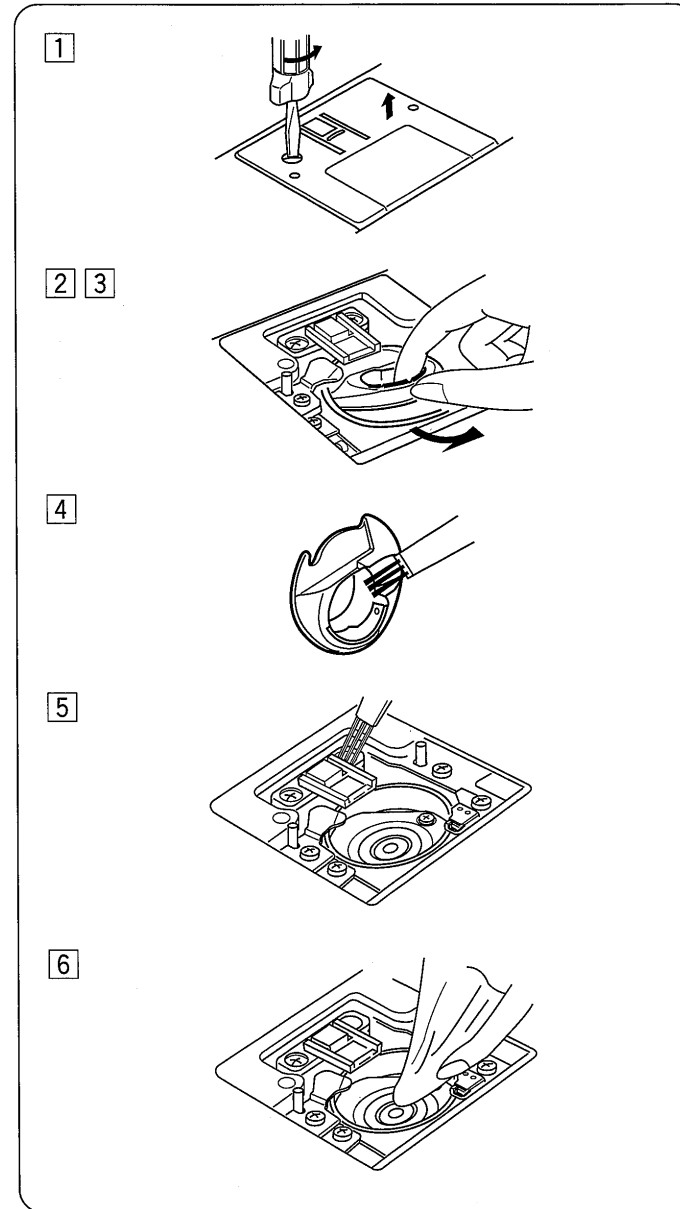

- 1 Remove the presser foot and needle. Remove the screw on the left side of the needle plate with the screwdriver supplied with the machine.
- 2 Remove the needle plate and take out the bobbin.
- 3 Lift up the bobbin holder and remove it.
- 4 Brush out dust and lint.
- 5 Clean the feed dogs and hook race with the lint brush.
- 6 Wipe out gently with soft, dry cloth.
* You may also use a vacuum cleaner.

Replacing the Bobbin Holder

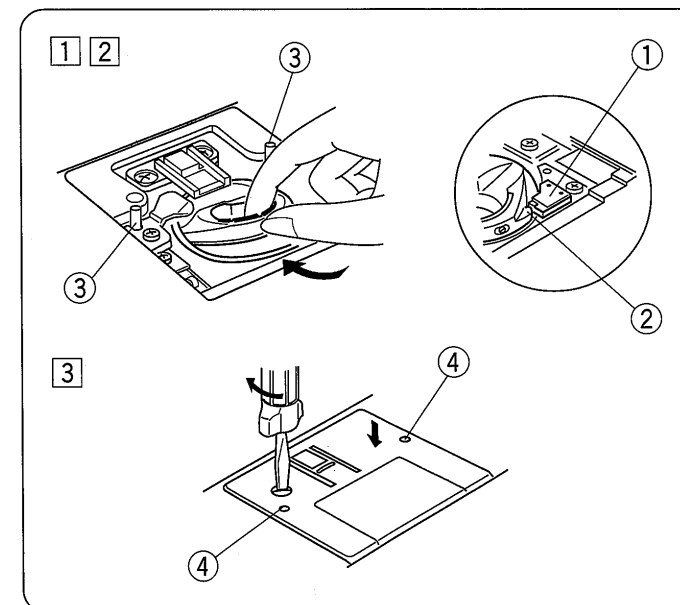

- 1 Insert the bobbin holder so that the knob fits next to the stopper in the hook race.
 - ① Stopper
 - ② Knob
 - 2 Insert the bobbin.
 - 3 Replace the needle plate, inserting the two needle plate guide pins into the holes in the needle plate. Replace the screw.
 - ③ Needle plate guide pins
 - ④ Guide hole
- After cleaning, be sure to replace the needle and presser foot.

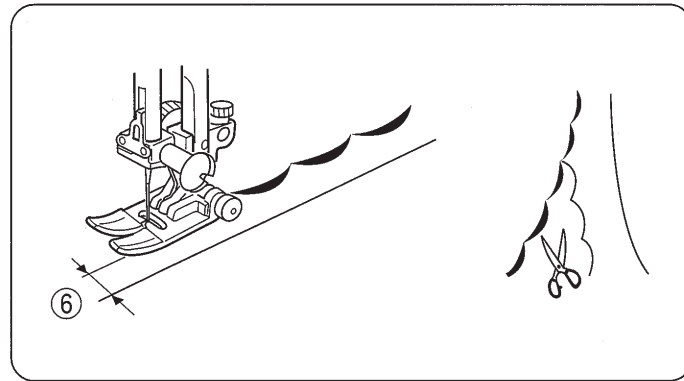
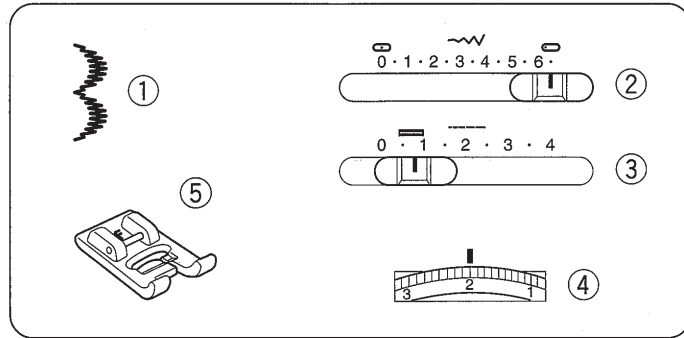

Scallop Hems

- ① Stitch selector: 10
- ② Stitch width: 3-6.5
- ③ Stitch length: 0.5-1
- ④ Top thread tension: 1-4
- ⑤ Presser foot: F: Satin stitch foot

Some of the craft patterns can be used to attractively finish the edges of collars, pockets and placements. To edge a collar, place interfacing between upper and under collar and sew the pattern on the seam line. After sewing, trim fabric close to stitching taking care not to cut thread.

⑥ 1cm (3/8")

Elastic Stitch

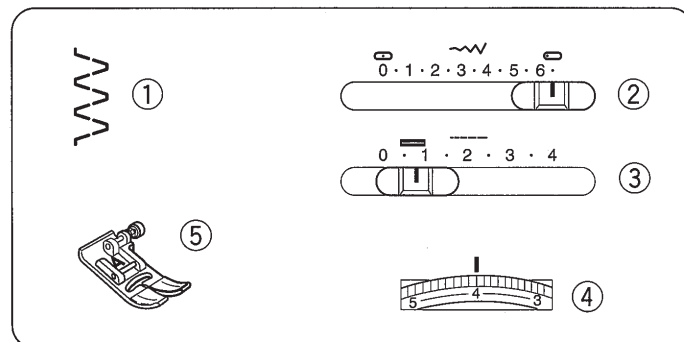
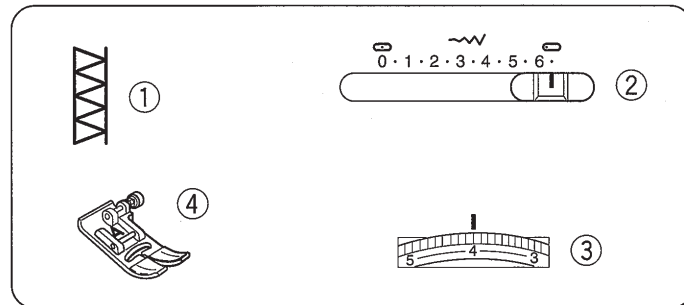

- ① Stitch selector: 14
- ② Stitch width: 5-6.5
- ③ Top thread tension: 3-6
- ④ Presser foot: A: Zigzag foot

- ① Stitch selector: 8
- ② Stitch width: 5-6.5
- ③ Stitch length: 0.5-1.5
- ④ Top thread tension: 3-6
- ⑤ Presser foot: A: Zigzag foot

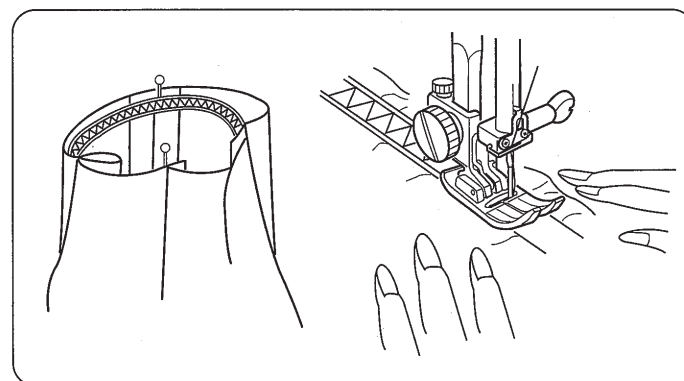

Choose this stitch to attach elastic to garments. Mark the elastic into quarters and match these to the center front, center back and side seams. Place the middle of the elastic under the center of the presser foot and stitch into place, making sure the elastic is evenly distributed.

Connecting Machine to Power Supply

- ① Power supply plug
- ② Power switch
- ③ Outlet
- ④ Machine socket
- ⑤ Machine plug

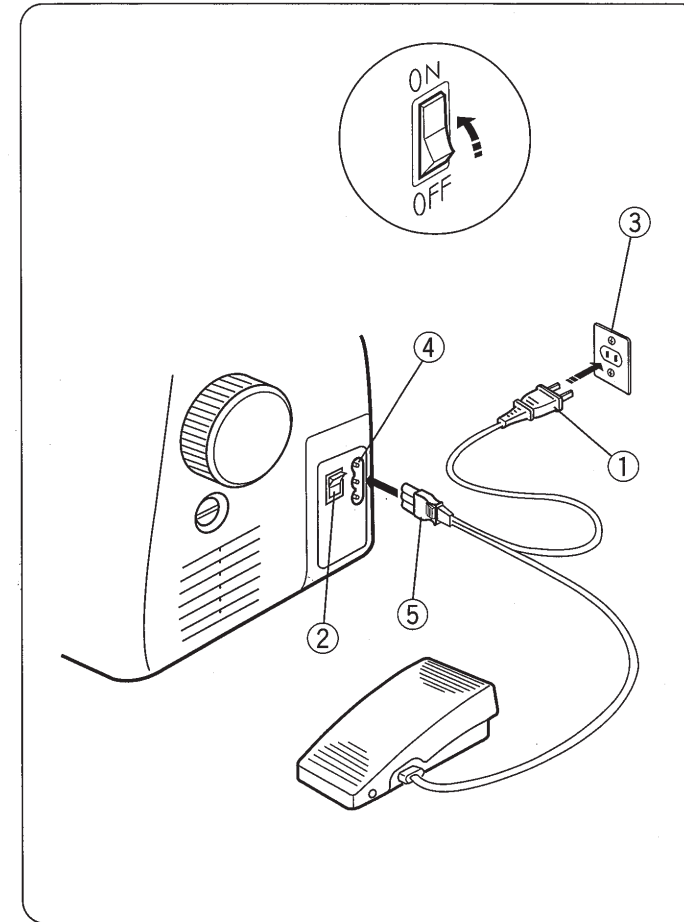

Before connecting the power cord, make sure the voltage and frequency shown on the machine conform to your electrical power.

1. Turn off the power switch ②.
2. Insert the machine plug ⑤ into the machine socket ④.
3. Insert the power supply plug ① into the outlet ③.
4. Turn the power switch ② to turn on the power and sewing light.

For Your Safety

1. While in operation, always keep your eye on the sewing area, and do not touch any moving parts such as the thread take-up lever, handwheel or needle.
2. Always turn off the power switch and unplug from the power supply:
 - * When leaving the machine unattended.
 - * When attaching or removing parts.
 - * When cleaning the machine.
3. Do not place anything on the foot control, except in use.

Operating Instructions:

The symbol "0" on a switch indicates the "off" position. "For appliances with a polarized plug (one blade wider than the other). To reduce the risk of electric shock, this plug is intended to fit in a polarized outlet only one way. If the plug does not fit fully in the outlet, reverse the plug. If it still does not fit, contact a qualified electrician to install the proper outlet. Do not modify the plug in any way." "Foot control Model TJC-150 or Model YC-482J-1-EC for use with this sewing machine" (For U.S.A. market only).

Foot Control

Sewing speed can be varied by the foot control. The harder you press on the control, the faster the machine runs.

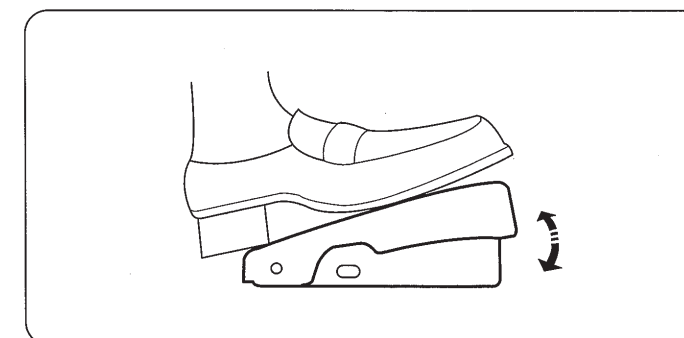

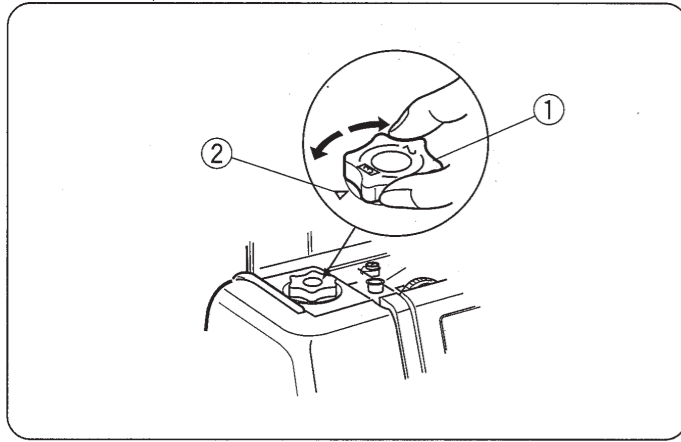

Pressure Dial

The pressure dial should be set at "3" for regular sewing. Reduce the pressure to "2" for appliqué, cutwork, drawn work, basting and embroidery. Set the pressure to "1" when sewing chiffon, lace, organdy and other fine fabrics. Velours and knits with a lot of stretch may also require a "1" setting.

- ① Pressure dial
- ② Setting mark

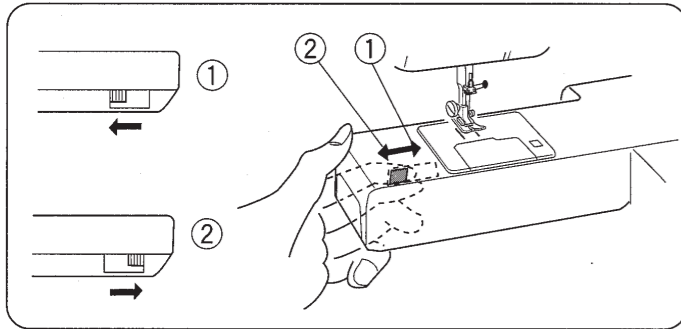

To Raise or Drop the Feed Dog

- For button sewing, etc., drop the feed dog.
 - After finished sewing, raise the feed dog.
- The feed dog must always be up for normal sewing.

- ① Lowered position
- ② Raised position

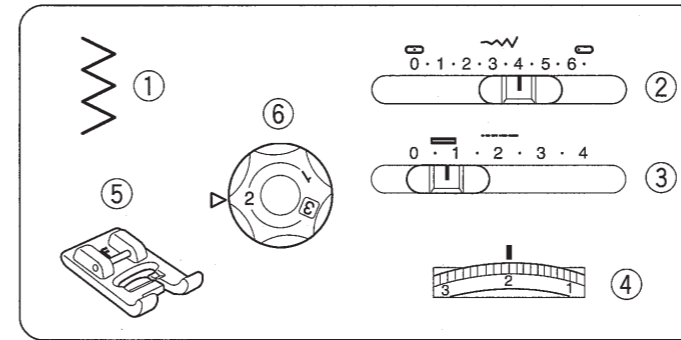

Appliqué

- ① Stitch selector: 3
- ② Stitch width: 3-5
- ③ Stitch length: 0.5-1
- ④ Top thread tension: 1-4
- ⑤ Presser foot: F: Satin stitch foot
- ⑥ Presser Dial: 2

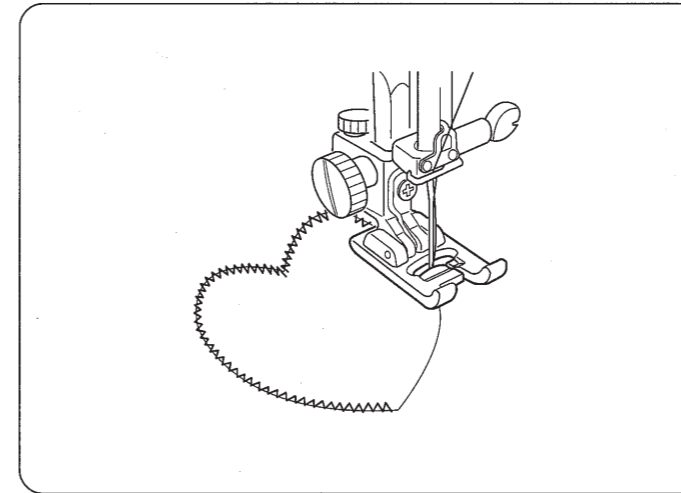

Baste (or fuse with iron-on fabric joiner) appliqué pieces on the fabric.

Stitch around the appliqué making sure the needle falls along the outer edge of the appliqué.

When sewing corners, lower the needle down into the fabric. Raise the presser foot and pivot the fabric to the right or left.

* When appliqué sewing is finished, return the pressure dial to 3.

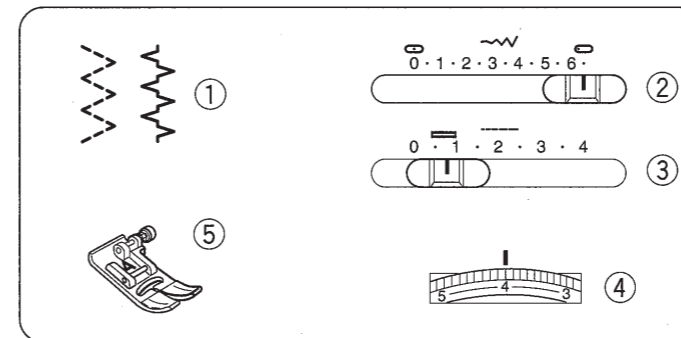

Patch Work

- ① Stitch selector: 5 or 7
- ② Stitch width: 5-6.5
- ③ Stitch length: 0.5-1
- ④ Top thread tension: 3-6
- ⑤ Presser foot: A: Zigzag foot

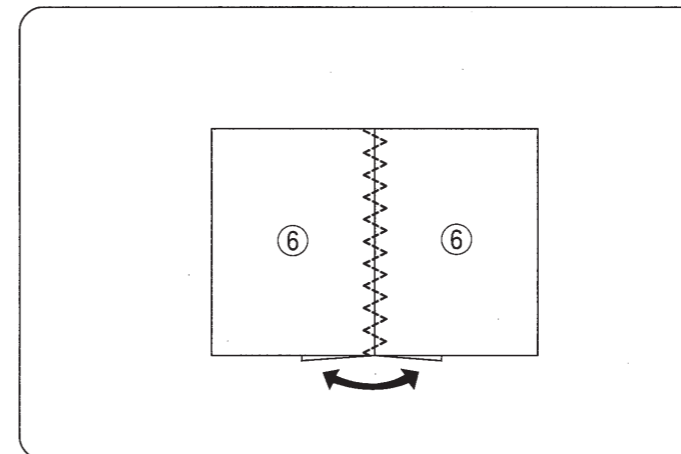

Sew seam and press seam allowance open.

Sew pattern stitch on right side of garment centering over the seam line.

- ⑥ Right side of fabric

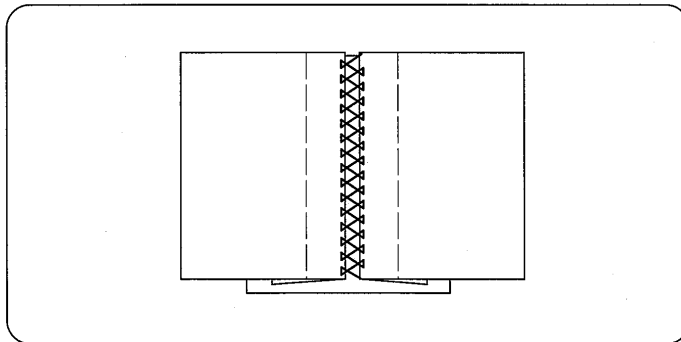
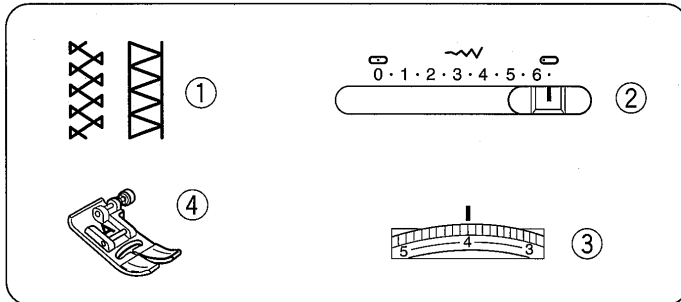
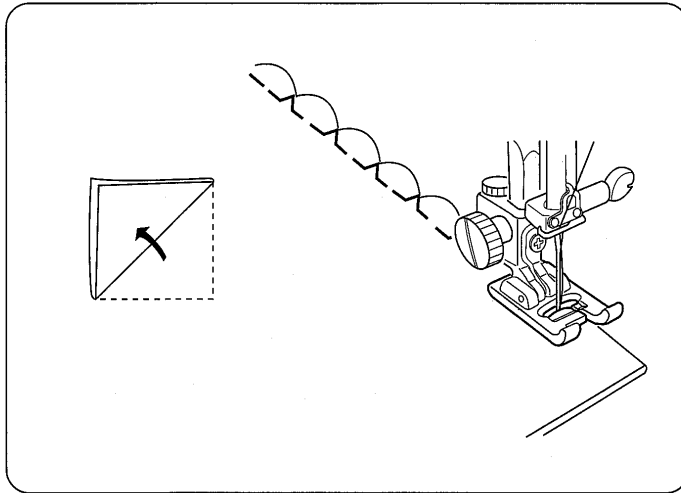
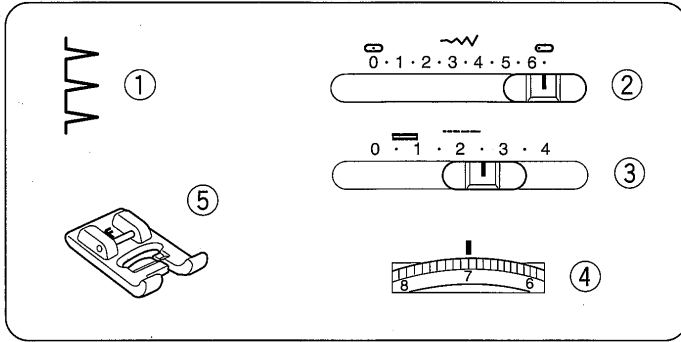

Shell Tuck

- ① Stitch selector: 6
- ② Stitch width: 5-6.5
- ③ Stitch length: 2-3
- ④ Top thread tension: 6-8
- ⑤ Presser foot: F: Satin stitch foot

* Use a lightweight fabric such as tricot. Fold and stitch on the bias. Set the stitch width and length as you desire. You may need to tighten the top thread slightly. Allow the needle to just clear the folded edge of the fabric when it zigzags. If you sew rows of shell stitches, space the rows 1.5 cm (5/8") apart. You can sew shell stitches on knits or soft silky wovens in any direction.

- ① Selected stitch
- ② F: Satin stitch foot

Fagoting

- ① Stitch selector: 12 or 14
- ② Stitch width: 5-6.5
- ③ Top thread tension: 3-6
- ④ Presser foot: A: Zigzag foot

Fold under 1.5 cm (1/2") on each fabric edge and press. Pin the two edges to paper 0.3 cm (1/8") apart. Sew slowly guiding the fabric so the needle catches the folded edge on each side.

To Remove and Attach Presser Foot

Press the red button on the back of the foot holder.

The presser foot will drop off.

Place the selected presser foot so the pin on the foot lies just under the groove of the foot holder. Lower the presser bar to lock the foot in place.

- ① Red button
- ② Groove
- ③ Pin

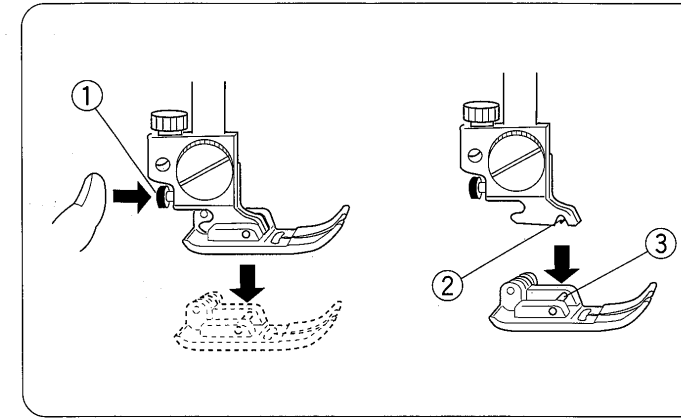

To Remove and Attach the Foot Holder

To Remove:

Remove the thumb screw by turning the screw counter-clockwise with the screwdriver.

- ① Thumb screw

To Attach:

Match the hole in foot holder with the threaded hole in the presser bar.

Fit the thumb screw into the hole.

Tighten the screw by turning it clockwise.

- ② Foot holder
- ③ Presser bar

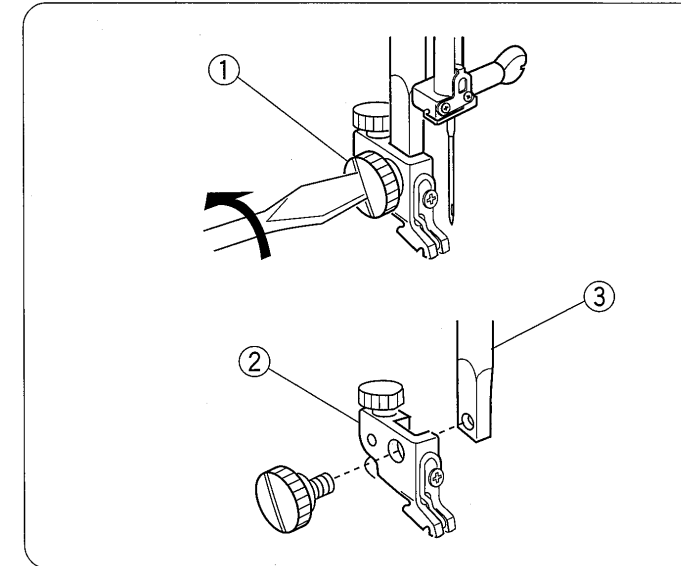

Reverse Button

For as long as you keep the reverse stitch button depressed, the machine sews backwards.

- ① Reverse button

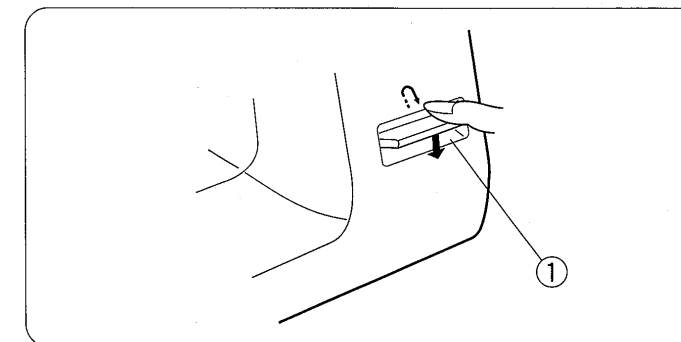

Presser Foot Lifter

The presser foot lifter raises and lowers your presser foot.

You can raise it about 0.6 cm (1/4") higher than the normal up position for easy removal of the presser foot or to help you place heavy fabric under it.

- ① Presser foot lifter
- ② Normal up position
- ③ High position

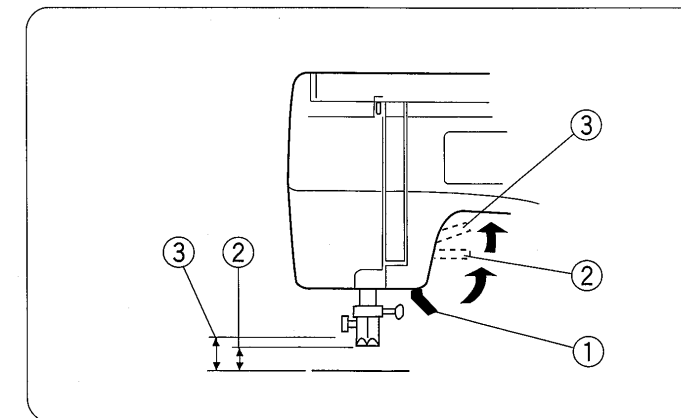

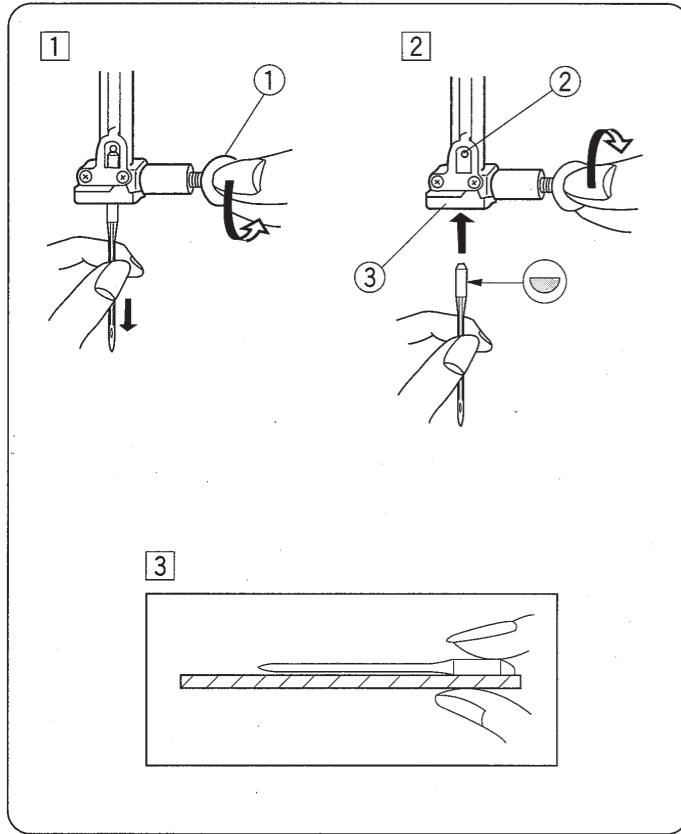

Changing Needle

- 1 Turn off the power switch. Raise the needle to its highest position by turning the handwheel counterclockwise and lower the presser foot. Loosen the needle clamp screw by turning it counterclockwise. Remove the needle from the clamp.
 - 2 Insert the new needle into the needle clamp with the flat side to the rear. When inserting the needle into the clamp, push it up as far as it will go and tighten the clamp screw firmly.
 - 3 To find a good needle, put the flat side of the needle onto something flat (a needle plate, glass, etc.). The gap between the needle and the flat surface should be consistent. Never use a bent or blunt needle.
- ① Needle clamp screw
② Pin
③ Needle clamp

Changing, Thread and Needle Chart

Fabric	Thread	Needle
Fine Lawn Georgette Tricot Organza Crepe	Silk #80-100 Cotton #80-100 Synthetic #80-100	#9/65-11/75 Blue tip needle
Medium Sheeting Jersey Broadcloth Fleece	Silk #50 Cotton #50-80 Synthetic #50-80	#11/75-14/90
Heavy weight Denim Tweed Coating Quilting	Silk #30-50 Cotton #40-50 Synthetic #40-50	#14/90-16/100

NOTE:
1 x blue tip needles (#11/75), 2 x #11/75 needles and 2 x #14/90 needles are included in the needle case (Part No. 540401026).

- For general sewing, use needle size 11/75 or 14/90.
- A fine thread and needle should be used for sewing lightweight fabrics, so the fabric will not be marred.
- Heavy fabrics require a needle large enough to pierce the fabric without fraying the needle thread.
- Always test the needle size on a small scrap of the fabric that will be used for actual sewing.
- In general, use the same thread for the needle and bobbin.
- When sewing stretch fabrics, very fine fabrics and synthetics, use a blue tip needle. The blue tip needle effectively prevents skipped stitches.

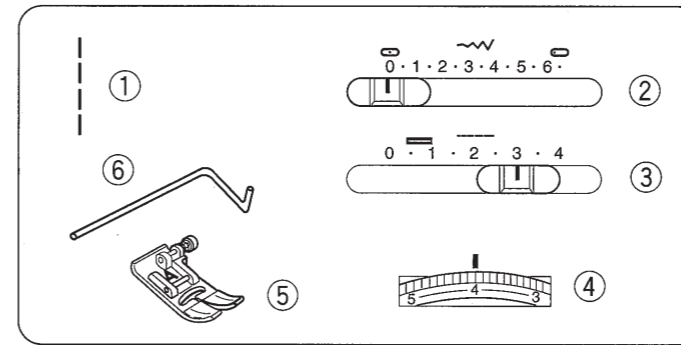

Quilting

- ① Stitch selector: 1
② Stitch width: 0
③ Stitch length: 1.5-4
④ Top thread tension: 3-6
⑤ Presser foot: A: Zigzag foot
⑥ Quilter

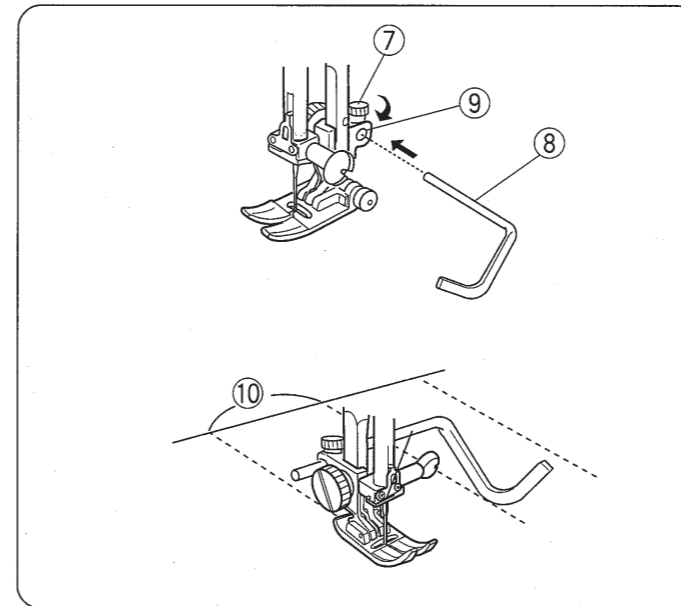

The quilting guide will help to keep the stitching lines straight. Loosen the quilter holding screw. Slide the quilter in the opening to the desired width and tighten the screw. Sew guiding the quilter over the previous row of stitching.

- ⑦ Quilter holding screw
⑧ Quilter
⑨ Hole
⑩ Distance

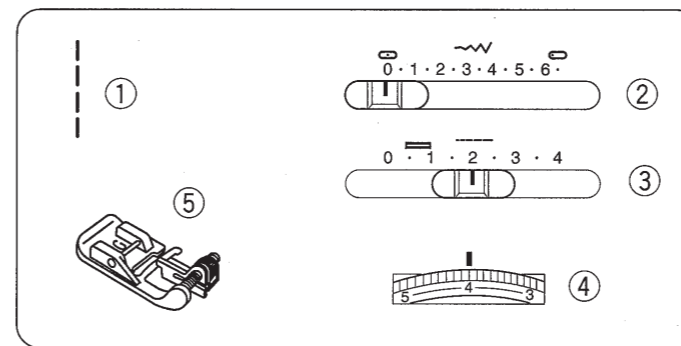

Pin Tucking

- ① Stitch selector: 1
② Stitch width: 0
③ Stitch length: 1.5-3
④ Top thread tension: 2-6
⑤ Presser foot: G: Blind stitch hem foot

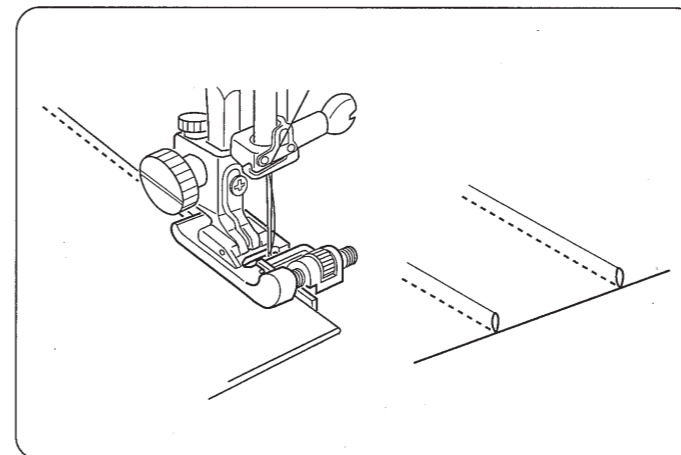

Fold the fabric with wrong sides together on the foldline. Position the fabric so that the needle pierces 0.1 to 0.2 cm (1/16") inside of folded part and lower the presser foot. Turn the guide screw and move the sliding guide next to the folded edge. Sew guiding the folded edge along the sliding guide. Press the pin tucks to one side.

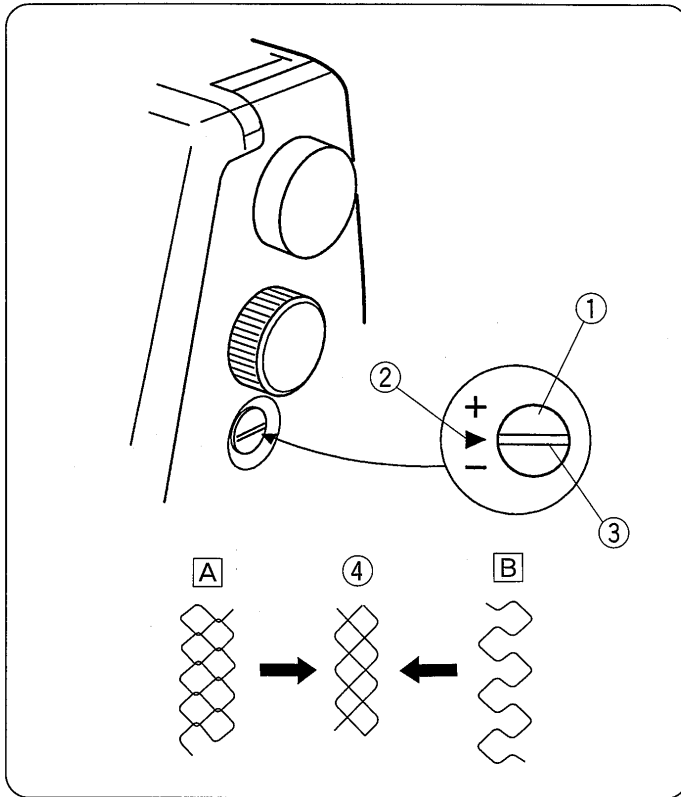

Adjusting Stretch Stitch Balance

If stretch stitch patterns are uneven when sewn on a particular fabric, adjust them with the feed balance dial.

- ① Feed balance dial
- ② Standard mark
- ③ Setting mark
- ④ Example: Pattern # 16

To Adjust distorted patterns

- A If patterns are compressed, correct by turning the dial in the direction of " + ".
- B If patterns are drawn out, correct by turning the dial in the direction of " - ".

Smocking

- ① Stitch selector: 16
- ② Stitch width: 3-6.5
- ③ Top thread tension: 1-4
- ④ Presser foot: A: Zigzag foot

With the manual stitch length at 4.5, sew straight lines 1 cm (3/8") apart, across the area to be smocked.

A looser needle thread tension will make gathering easier. Knot the threads along one edge. Pull the bobbin threads and distribute the gathers evenly.

Secure the threads at the other end.

Reduce the tension and pressure if necessary and sew pattern stitches between the straight seams.

Pull out the gathering stitches.

- ⑥ 1 cm (3/8")

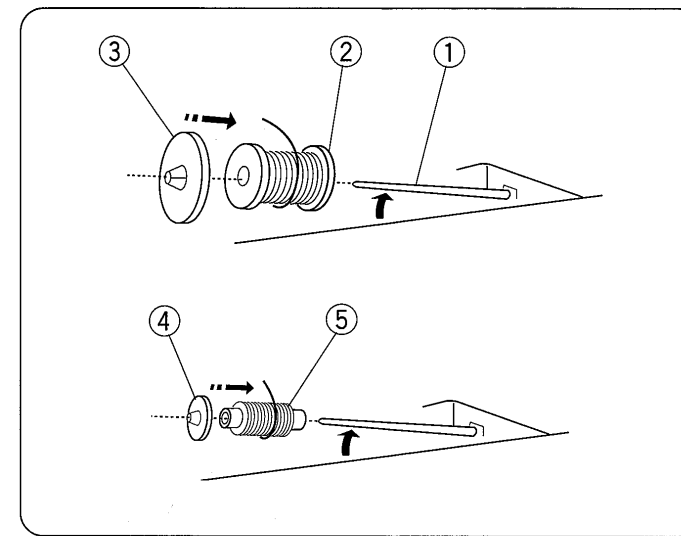
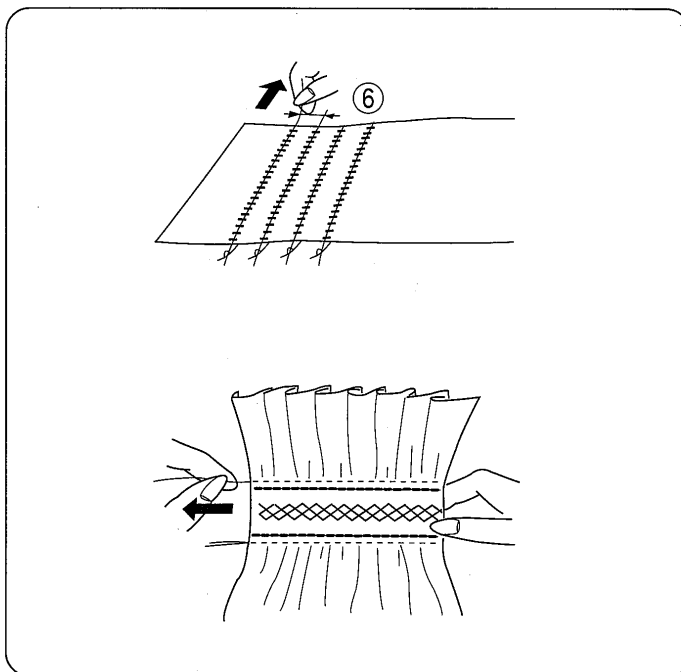
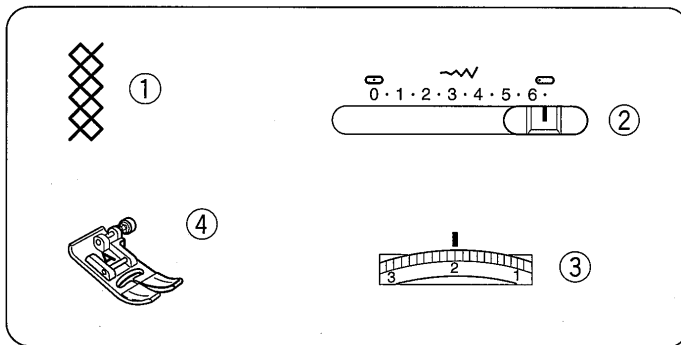

Winding the Bobbin

• Set the Spool

Lift up the spool pin and place the spool of thread on it with the thread coming off the spool as shown.

Press the large spool holder firmly against the spool of thread.

* The small spool holder is used with small or narrow spools of thread.

- ① Spool pin
- ② Ordinary spool
- ③ Large spool holder
- ④ Small spool holder
- ⑤ Small spool

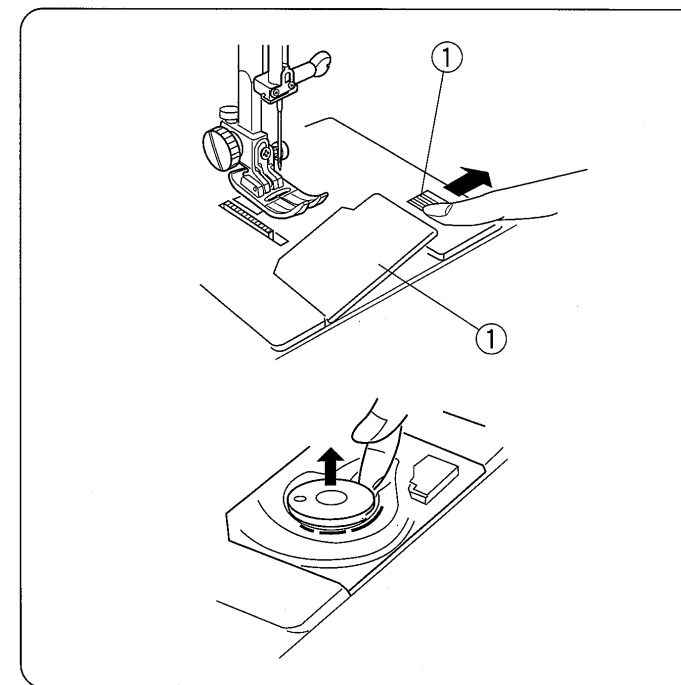

• Removing the Bobbin

Gently slide the hook cover plate release button to the right and remove the cover plate.

Lift out the bobbin.

- ① Hook cover plate release button
- ② Hook cover plate

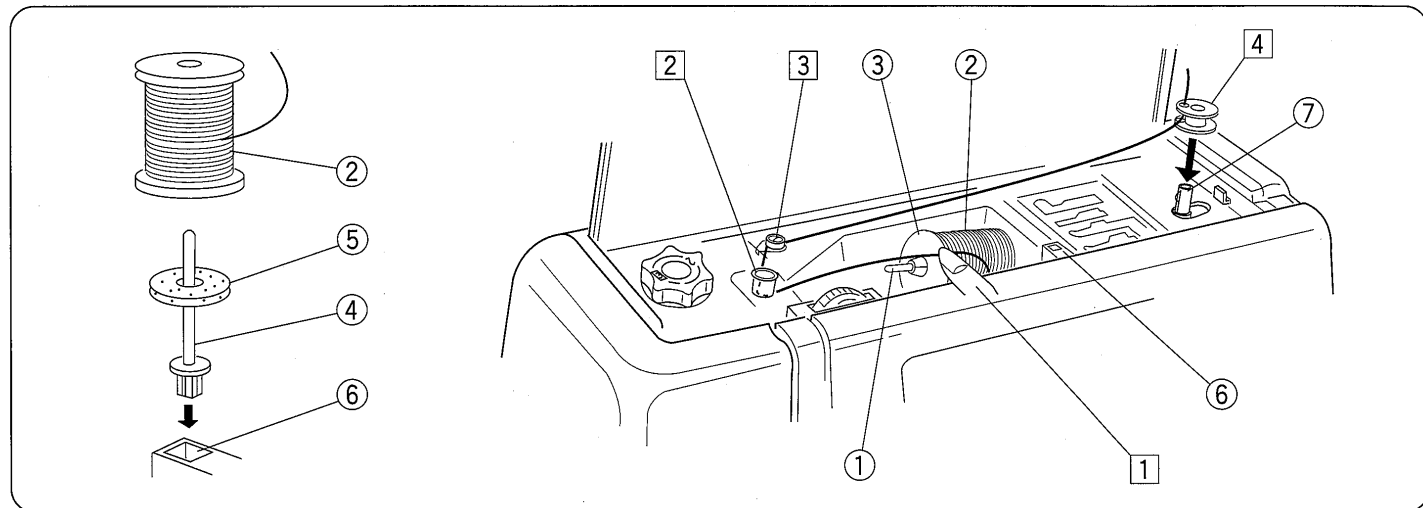

• Winding the Bobbin

1 Lift up the spool pin. Place the spool of thread on the spool pin with the thread coming off the spool as shown. Attach the large spool holder, and press it firmly against the spool of thread.

* The small spool holder is used with narrow or small spools of thread.

* To use the additional spool pin, guide the upper thread as shown in 2, 3.

2 Guide the thread around the thread guide.

3 Pass the thread through the thread guide.

4 Thread through the hole in the bobbin from the inside to outside. Put the bobbin on the bobbin winder spindle.

5 Push the bobbin to the right.

6 With the free end of the thread held in your hand, depress the foot control. Stop the machine when it has made a few turns, and cut the thread close to the hole in the bobbin.

7 Depress the foot control again. When the bobbin is fully wound, it will stop automatically. Return the bobbin winder to its original position by moving the spindle to the left, and cut the thread as shown.

* The machine will not sew until the spindle is in the left position.

- 1 Spool pin
- 2 Spool
- 3 Spool holder
- 4 Additional spool pin
- 5 Felt
- 6 Additional spool pin hole
- 7 Bobbin winder spindle

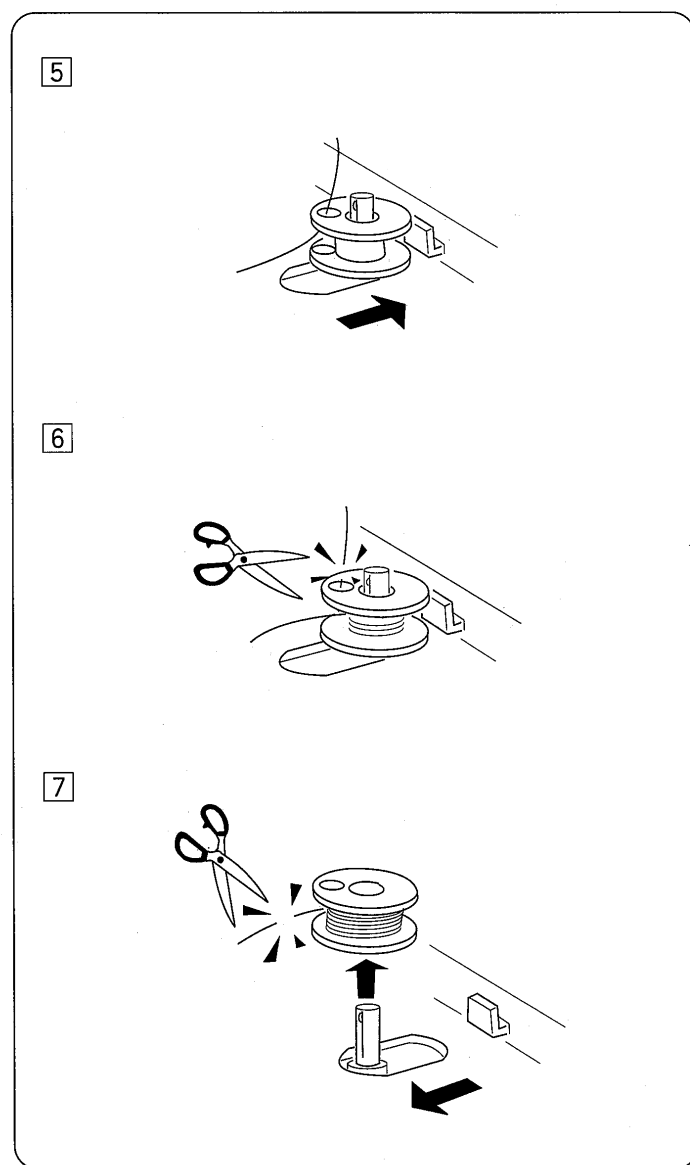

Decorative Satin Stitch Patterns

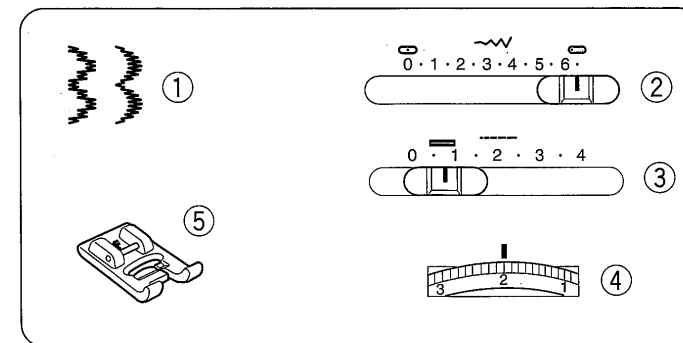

- 1 Stitch selector: 9-10
- 2 Stitch width: 3-6.5
- 3 Stitch length: 0.5-1
- 4 Top thread tension: 1-4
- 5 Presser foot: F: Satin stitch foot

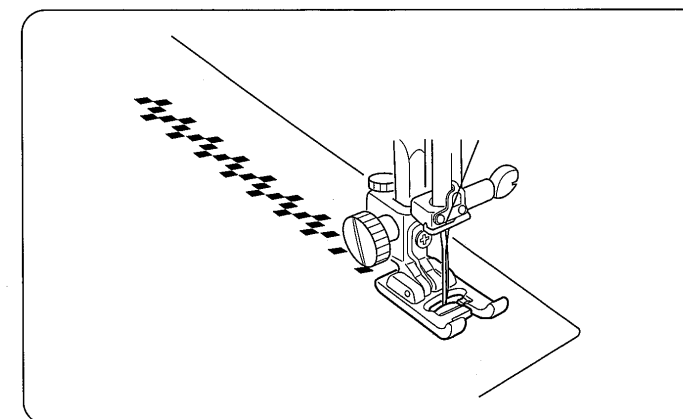

For a delicate appearance on fabric such as chiffon, use a single layer with a tear-away backing if necessary.

Stretch Stitch Patterns

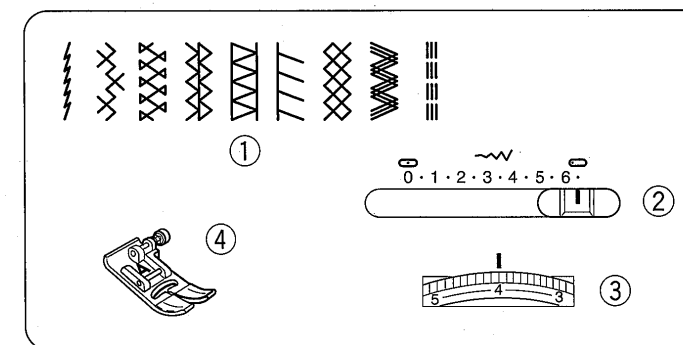

- 1 Stitch selector: 2, 11-18
- 2 Stitch width: 3-6
- 3 Top thread tension: 3-6
- 4 Presser foot: A: Zigzag foot

* The stitch length slider has no effect on the stretch patterns (they are preset).

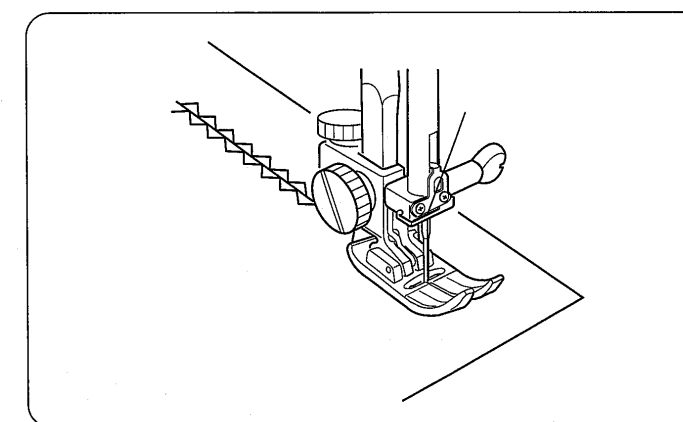

As the sewing fabric moves forward and backward during stretch stitch sewing, be careful to guide it straight by hand.

* We recommend a blue tip needle for stretch, knit or organdy fabrics to prevent skipping stitches.

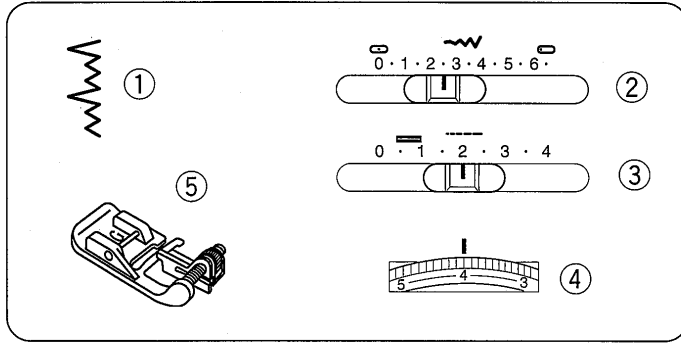

Blind Stitch Hemming

- ① Stitch selector: 4
- ② Stitch width: 2-3
- ③ Stitch length: 1-3
- ④ Top thread tension: 2-6
- ⑤ Presser foot: G: Blind stitch hem foot

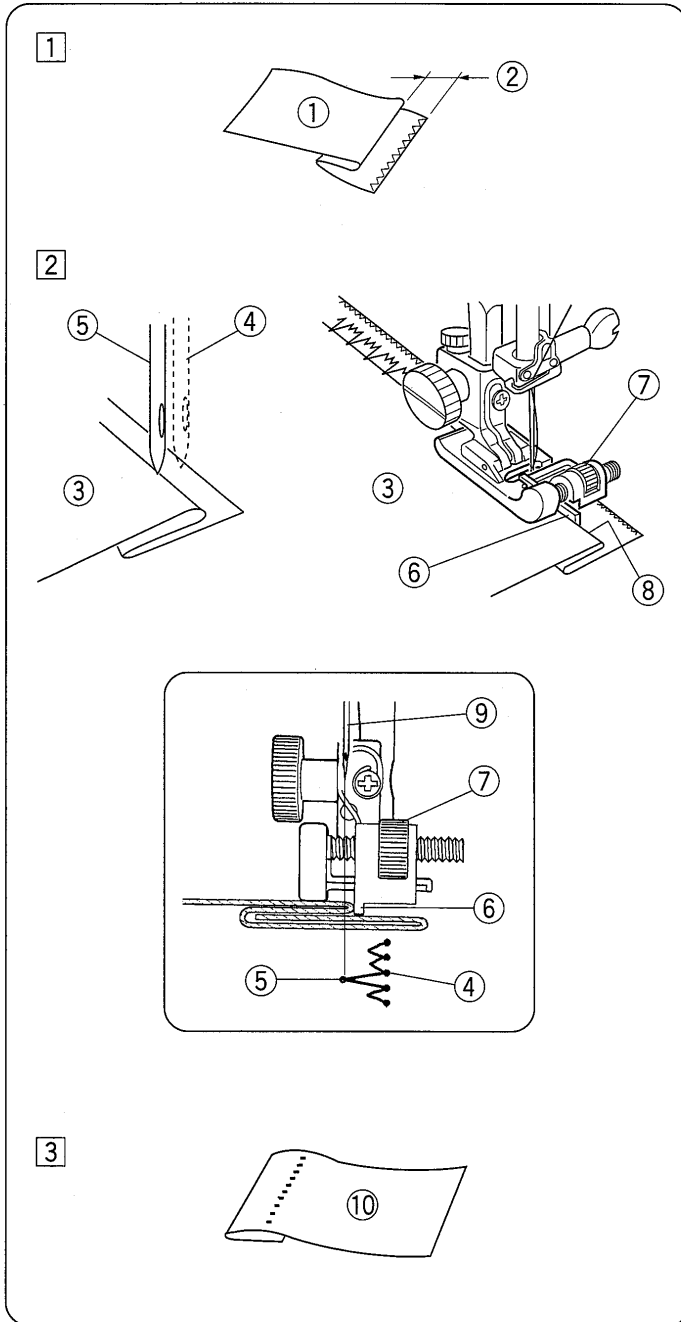

1 How to fold the fabric.

- ① Wrong side of fabric
- ② 0.4-0.7 cm (5/32" - 1/4")

2 Sewing technique and guide setting.

- * When the needle comes to the left hand side, position the fabric so that the folded edge comes to the left side of the guide. Lower the presser foot.
- * Adjust the position of the needle sewing with the stitch width key so that the needle just pierces the folded edge of the fabric when the needle comes to the left side. Sew guiding the folded edge along the guide.

- ③ Wrong side of fabric
- ④ When the needle comes to right side
- ⑤ When the needle comes to left side
- ⑥ Guide
- ⑦ Guide dial
- ⑧ Folded edge
- ⑨ Needle

3 Open the fabric after sewing.

- ⑩ Right side of fabric

Note:

For a professional looking hem, try not to let the needle pierce more than 1/8" (0.2 cm) into the fold.

If the folded edge is pierced too far to left side, you can not expect a good seam on the right side of the fabric.

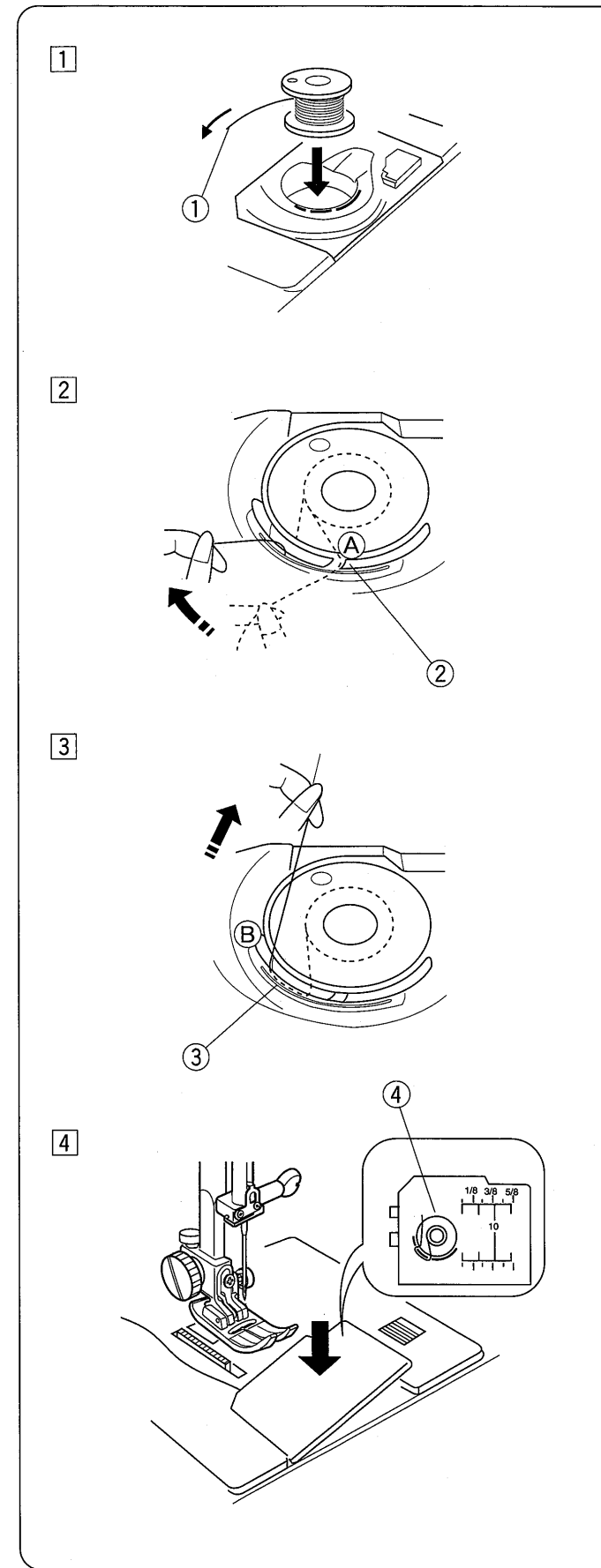

• Inserting the Bobbin

- 1 Place the bobbin in the holder with the thread running off counterclockwise.

- ① End of thread

- 2 Guide the thread into the notch A on the front side of the bobbin holder.

Draw the thread to the left, sliding it between the tension spring blades.

- ② Notch A

- 3 Continue to draw the thread lightly until the thread slips into notch B.

Pull out about 15 cm (6") of thread.

- ③ Notch B

- 4 Attach the hook cover plate.

Check the threading by referring to the chart shown on the hook cover plate.

- ④ Threading chart

Threading the Machine

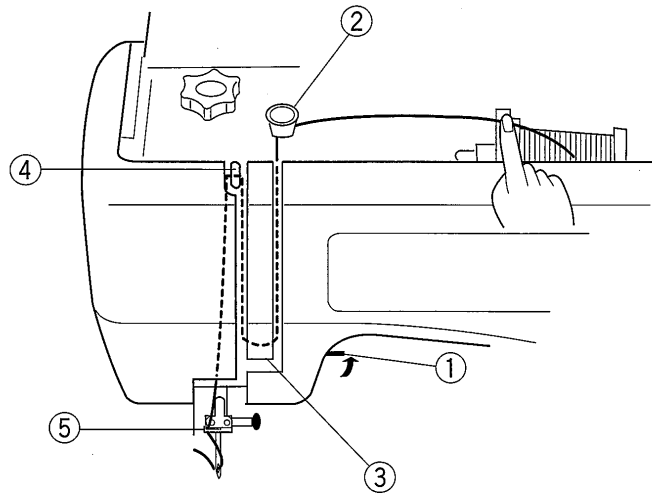

* Raise the presser foot lifter.

① Presser foot lifter

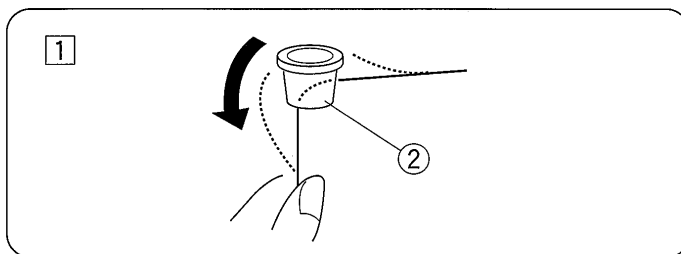

① Lead the thread from the spool and pass it through the thread guide. Then draw it down along the right slot.

② Thread guide

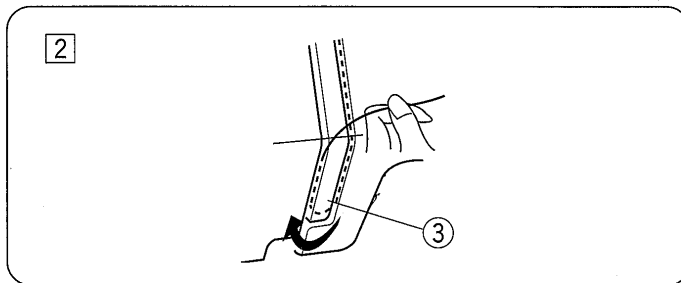

② Then, down around the check spring holder.

③ Check spring holder

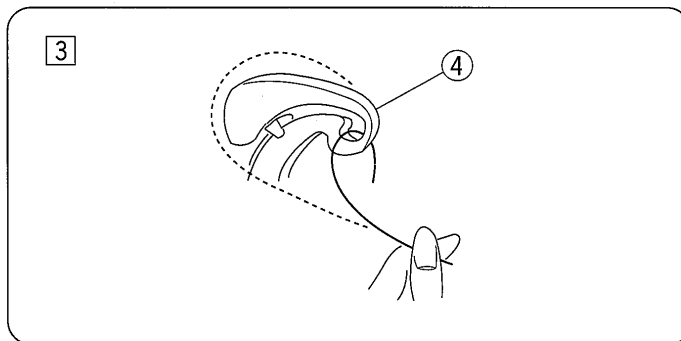

③ Firmly draw the thread from right to left over the take-up lever and down into the take-up lever eye.

④ Thread take-up

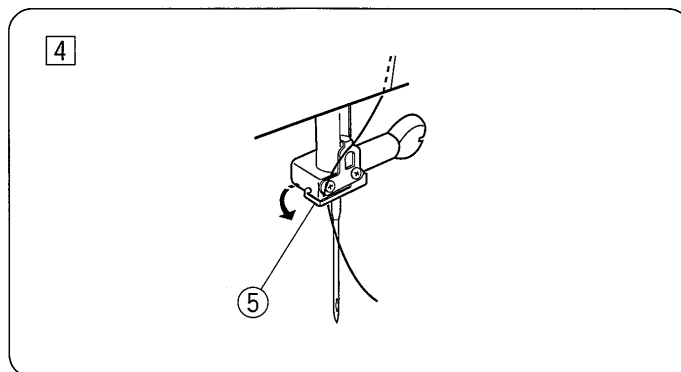

④ Slide the thread behind the needle bar thread guide on the left. Thread the needle from front to back or use the needle threader.

⑤ Needle bar thread guide

Rolled Hem

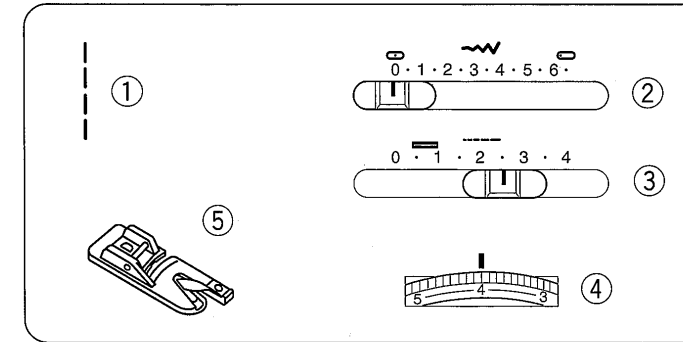

① Stitch selector: 1
 ② Stitch width: 0
 ③ Stitch length: 1.5-4
 ④ Top thread tension: 3-6
 ⑤ Presser foot: D: Hemmer foot

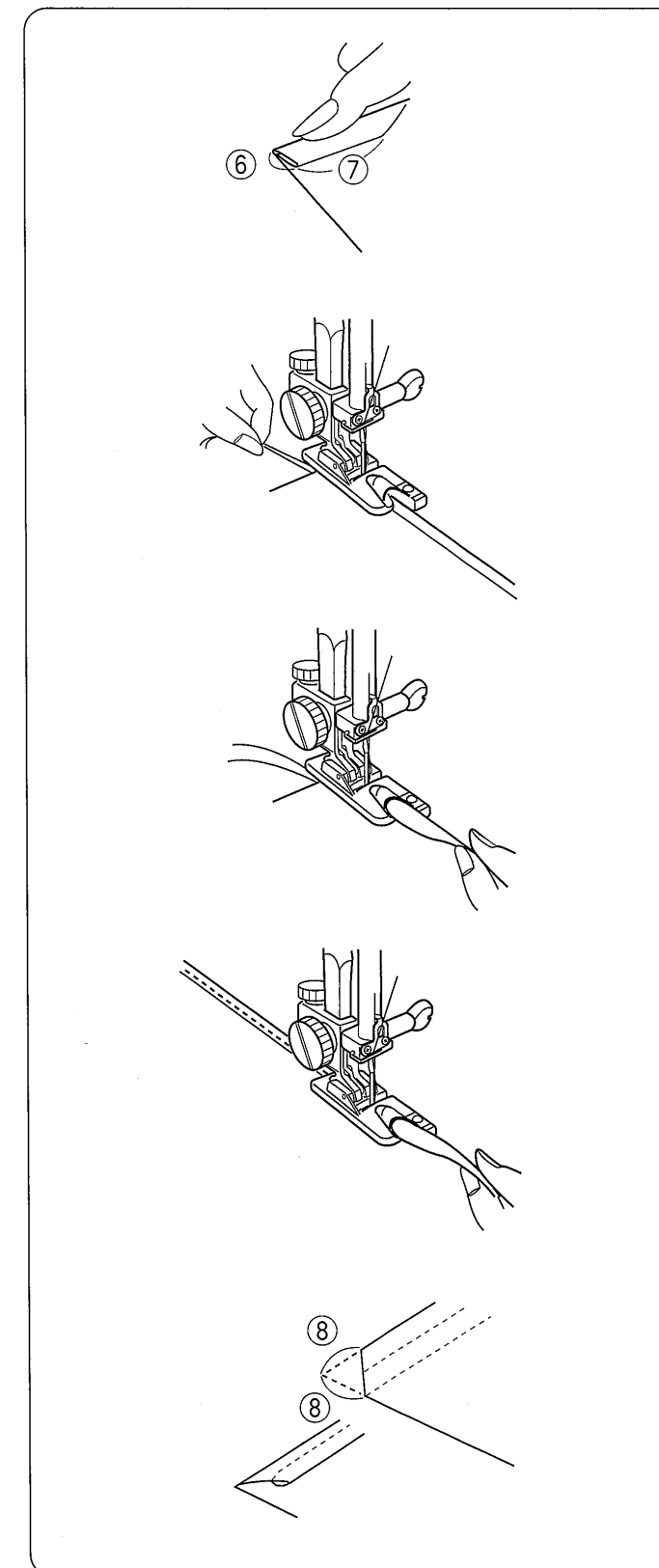

① Make a double 0.25cm (1/8") fold approximately 8 cm (3") in length.

⑥ 0.25 cm (1/8")

⑦ 8 cm (3")

② Lower the needle into the fabric at the point where sewing is to begin and lower the hemmer foot.

Sew 3 or 4 stitches while holding the needle and bobbin threads.

③ Lower the needle into the fabric and lift the hemmer foot.

Insert the folded portion of the fabric into the curl of the hemmer foot.

④ Lower the hemmer foot, then sew by lifting up the edge of the fabric to keep it feeding smoothly.

⑤ Trim about 0.7 cm (1/4") from corners as illustrated, to reduce bulk.

⑧ 0.7 cm (1/4")

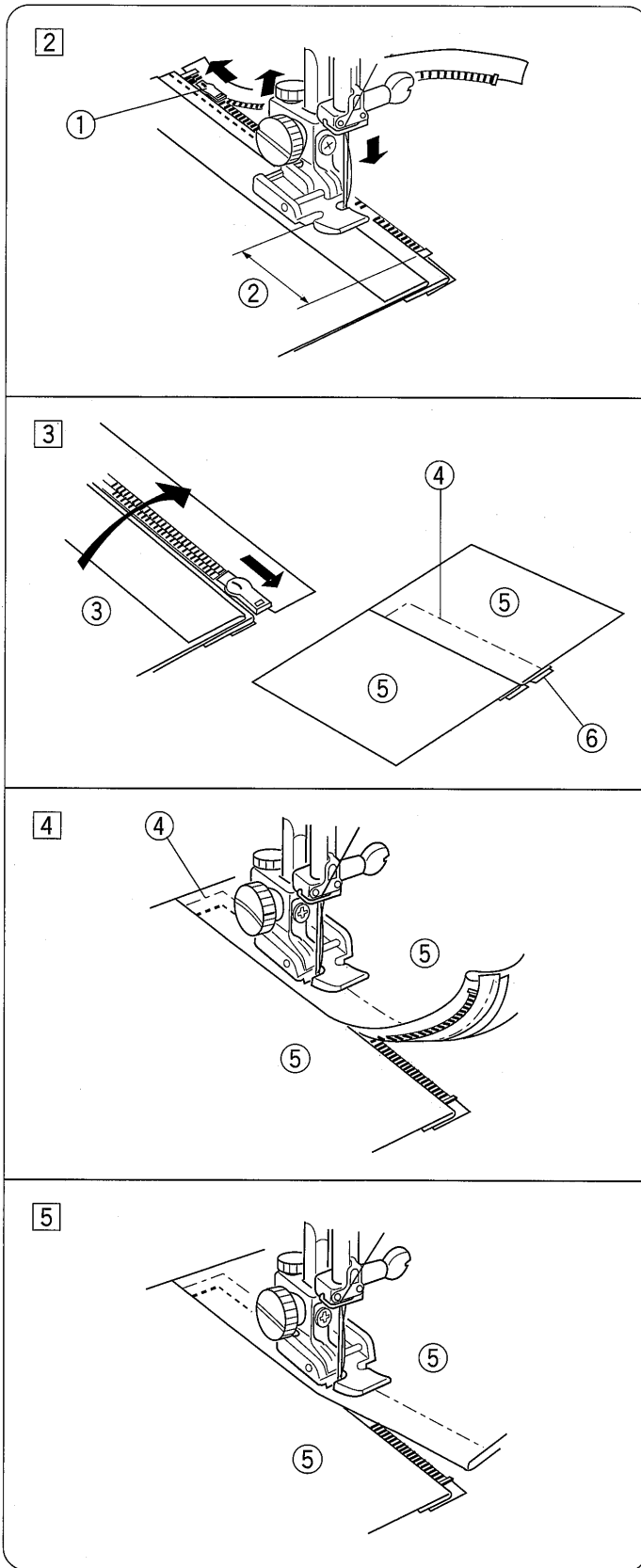

Zipper Sewing, cont'd

- 2 Sew through all layers next to fold. Stop just before the zipper foot reaches the slider on the zipper tape. Lower the needle slightly into the fabric. Raise the zipper foot and open the zipper. Lower the foot and stitch the remainder of the seam.
 - 1 Slider
 - 2 5 cm (2")
- 3 Close the zipper and spread the fabric flat with the right side facing up. Baste the opened fabric and zipper tape together.
 - 3 Wrong side of upper fabric
 - 4 Basting stitch
 - 5 Right side of fabric
 - 6 Zipper tape
- 4 Remove the zipper foot and reattach it on its left side. Guide the edge of the foot along the zipper teeth and stitch through the garment and zipper tape. Stop about 5 cm (2") from the top of the zipper.
- 5 Lower the needle slightly into the fabric, raise the foot, remove the basting stitches and open the zipper. Lower the foot and stitch the remainder of the seam, making sure the fold is even.

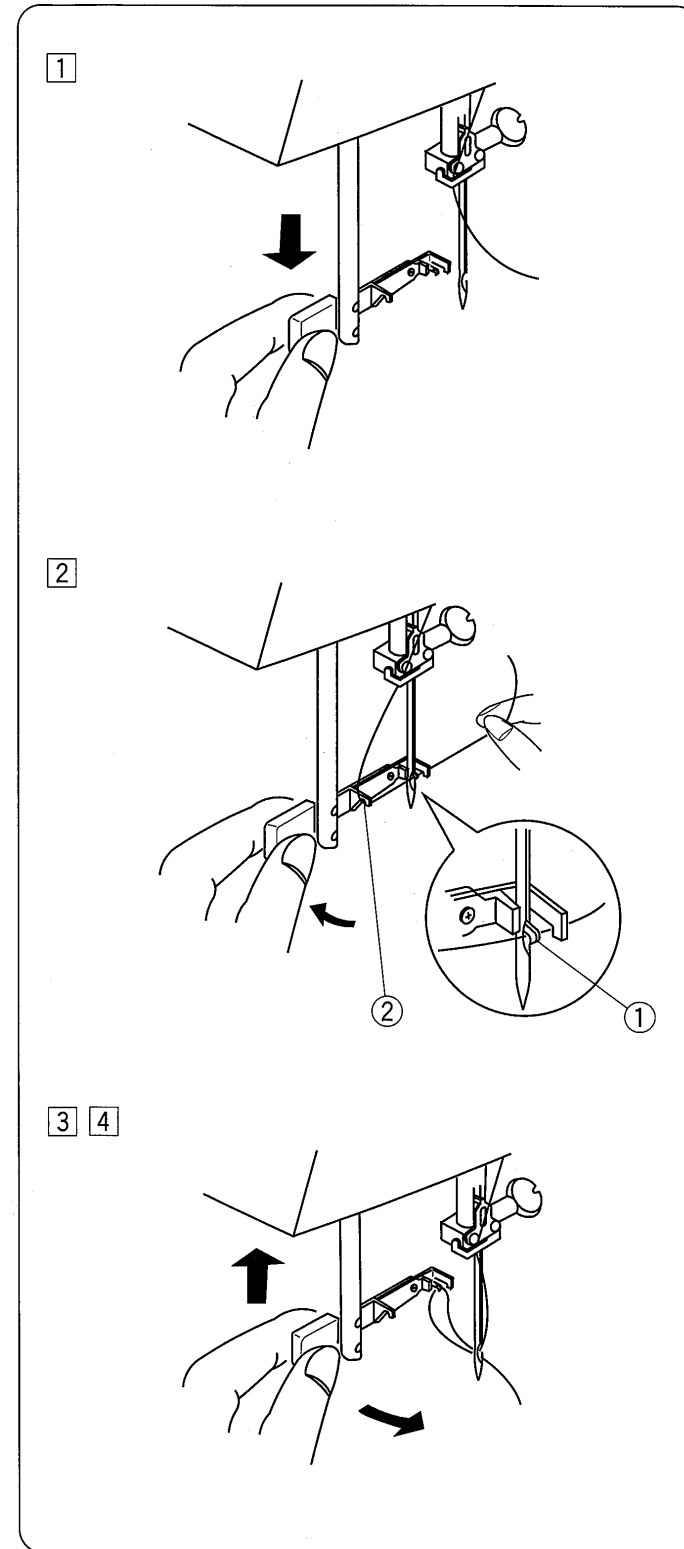

• Needle Threader

- 1 Raise the needle to its highest position. Pull down the needle threader knob as far as it will go.
 - 2 Turn the knob in the direction of the arrow in the illustration, then insert Hook 1 into the needle eye. Lead the thread around Guide 2 and under Hook 1.
 - 3 Turn the knob in the direction of the arrow in the illustration, drawing the thread loop through the needle.
 - 4 Pull the thread through the needle eye.
 - * The needle threader can be used with a #11 to #16 needle or a Janome Blue Tip needle. Thread size 50 to 100 should also work well.
- 1 Hook
 - 2 Guide

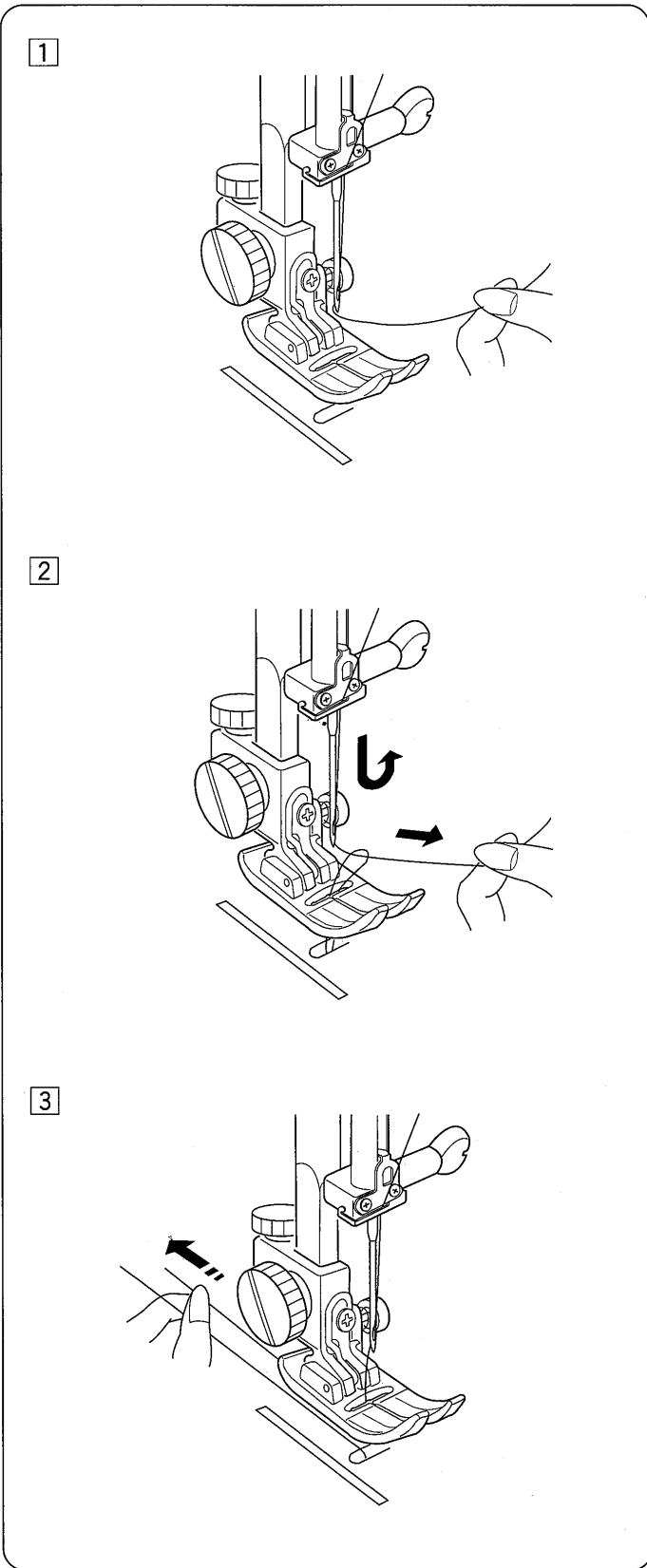

• Drawing Up the Bobbin Thread

1 Raise the presser foot. Hold the needle thread lightly with your left hand.

2 Turn the handwheel slowly towards you with your right hand until the needle goes down and continue turning the handwheel until the take-up lever is at its highest position. Lightly draw up the needle thread forming a loop of the bobbin thread.

3 Slide 10 cm (4") of both threads to the back under the presser foot.

Zipper Sewing

- ① Stitch selector: 1
- ② Stitch width:
- ③ Stitch length: 1.5-4
- ④ Top thread tension: 3-6
- ⑤ Presser foot: E: Zipper foot

• To Snap On the Zipper Foot

Fit the pin on the zipper foot into the groove on the foot holder.

- * To sew the left side of the zipper, attach the zipper foot on the right-hand side.
- * To sew the right side of the zipper, attach the zipper foot on the left-hand side.

- ① Groove
- ② Pin
- ③ When the left side is sewn.
- ④ When the right side is sewn.

• Fabric Preparation

Add 1 cm (3/8") to the zipper size. This is the overall opening size.

- ① Right side of fabric
- ② Opening size
- ③ Zipper size
- ④ 1 cm (3/8")
- ⑤ End of opening
- ⑥ Slider
- ⑦ Zipper teeth
- ⑧ Zipper tape

Place right sides of fabric together and sew to the end of the zipper opening. Reverse stitch to lock the stitches.

Manually increase the stitch length to 4 and sew the zipper opening.

- ⑨ 4 (Stitch Length)
- ⑩ End of opening
- ⑪ Reverse stitch
- ⑫ Straight Stitch
- ⑬ 2 cm (3/4")

• To Sew

1 Fold back the left seam allowance. Turn under the right seam allowance to form a 0.2 to 0.3 cm (1/8") fold. Place the zipper teeth next to this fold and pin in place.

Attach the zipper foot with the pin on the right hand side. Lower the zipper foot on the top side at the bottom of the zipper so that the needle pierces the fabric next to the fold and the zipper tape.

- ① Fold
- ② 0.3 cm (1/8")
- ③ Stitch line
- ④ End of opening
- ⑤ Opening size
- ⑥ Low fabric
- ⑦ Wrong side of fabric

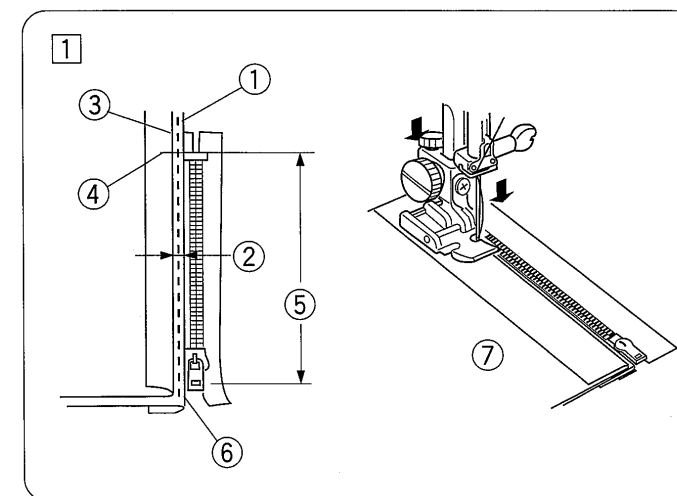
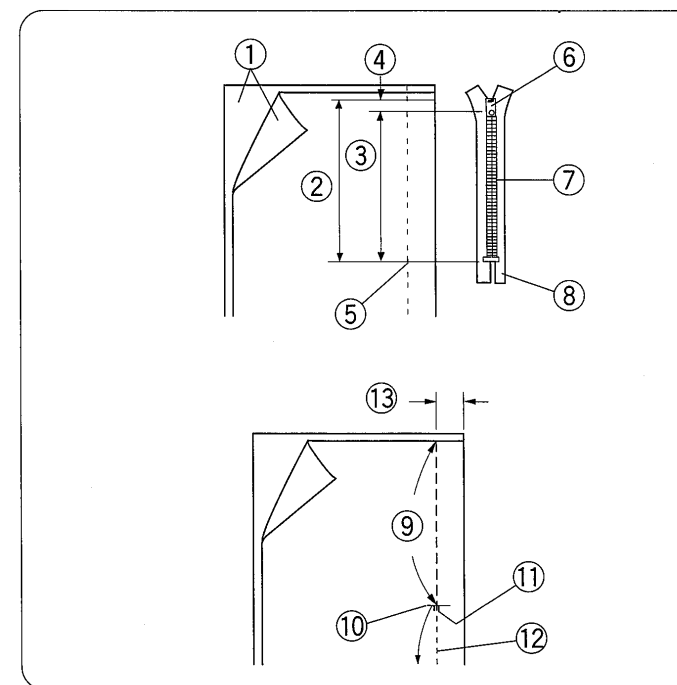
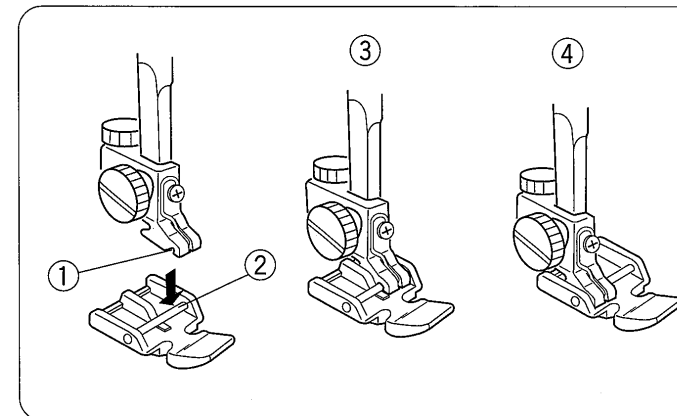
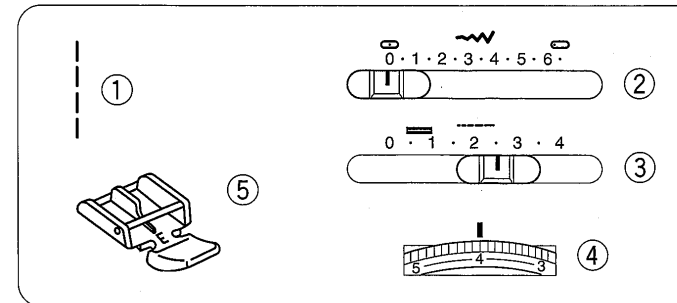

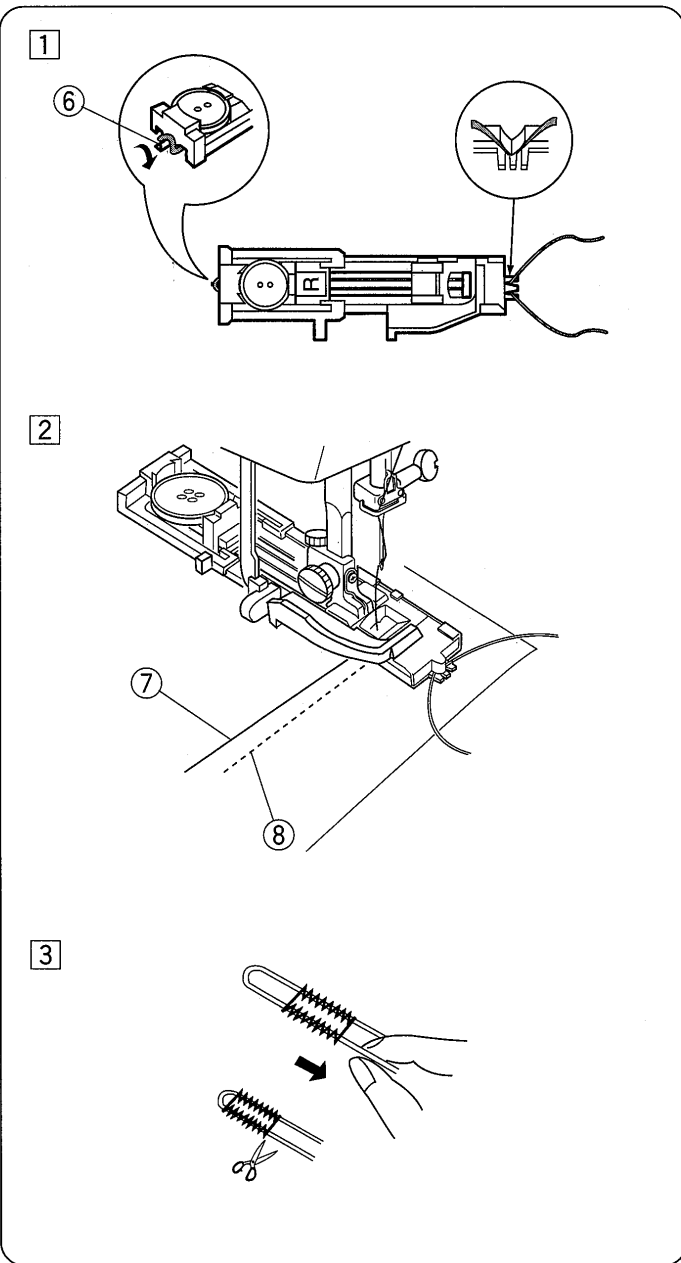
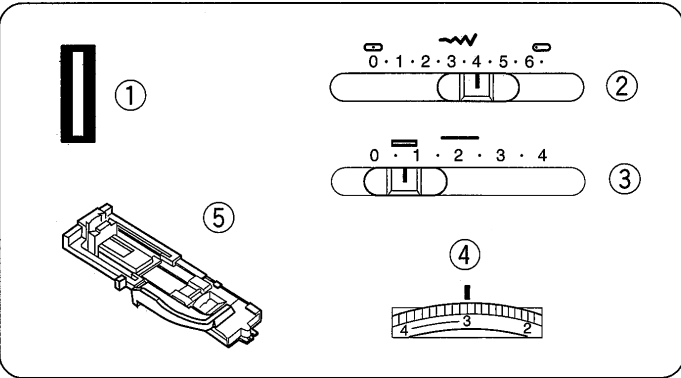

Corded Buttonholes

- ① Stitch selector: BH
- ② Stitch width: 4-6.5
- ③ Stitch length: 1-5
- ④ Top thread tension: 1-5
- ⑤ Presser foot: R: Automatic buttonhole foot

- 1 Use the same procedure as automatic buttonhole.
 - * Set the stitch width to match the thickness of the cord used.
- ⑥ With the buttonhole foot raised, hook the filler cord on the spur at the back of the buttonhole foot.

Bring the ends toward you under the buttonhole foot, clearing the front end. Hook the filler cord into the forks on the front of automatic buttonhole foot R to hold them tight.

Lower the needle into the garment where the buttonhole will start and lower the foot.
- 2 Depress the foot control gently and sew the buttonhole. Each side of the buttonhole and the bartacks will be sewn over the cord.

Remove the fabric from the machine and cut the sewing threads only.

 - ⑥ Spur
 - ⑦ Needle thread
 - ⑧ Bobbin thread
- 3 Pull the left end of the filler cord to tighten it. Thread the end through a darning needle, draw to the wrong side of the fabric and cut.
 - * To cut the buttonhole opening, refer to the instructions on page 24.

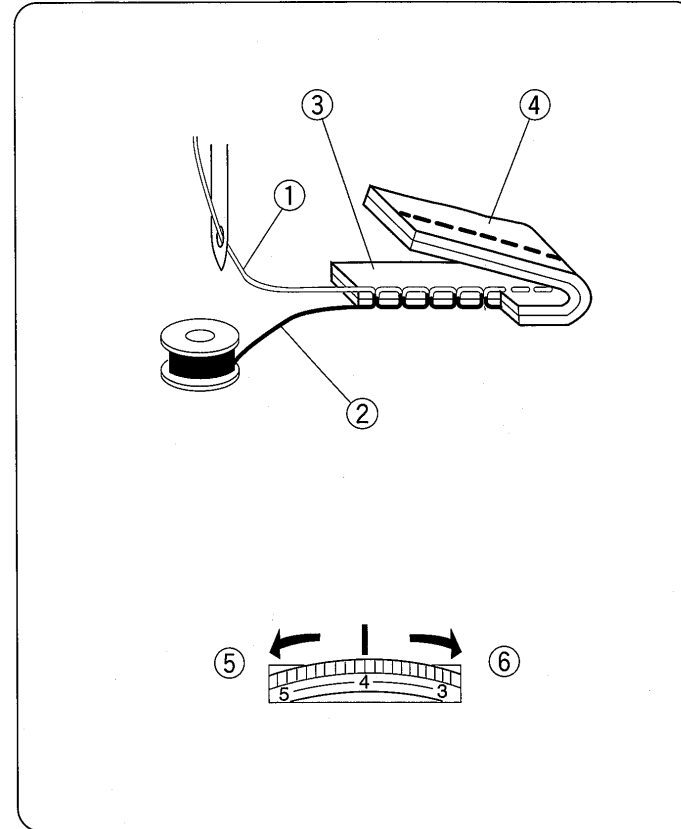

Adjust the Top Thread Tension

• Choose the Correct Tension

For Straight Stitch:
The ideal straight stitch will have threads locked between the two layers of fabric, as shown left (magnified to show detail). If you look at the top and bottom of the seam, you will notice that there are no gaps; that each stitch is smooth and even. When adjusting the top thread tension, the higher the number, the tighter the top thread. Results depend on;

- * stiffness and thickness of the fabric
- * number of fabric layers
- * type of stitch

- ① Needle thread (Top thread)
- ② Bobbin thread (Bottom thread)
- ③ Right side of fabric
- ④ Wrong side of fabric
- ⑤ To loosen
- ⑥ To tighten

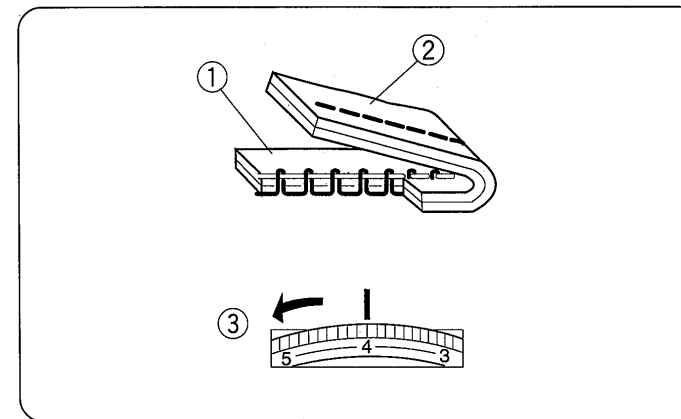

• Tension is too tight

The bobbin thread shows through on the right side of the fabric and it will feel bumpy. Turn the dial to the left to loosen the top thread tension.

- ① Right side of fabric
- ② Wrong side of fabric
- ③ To loosen

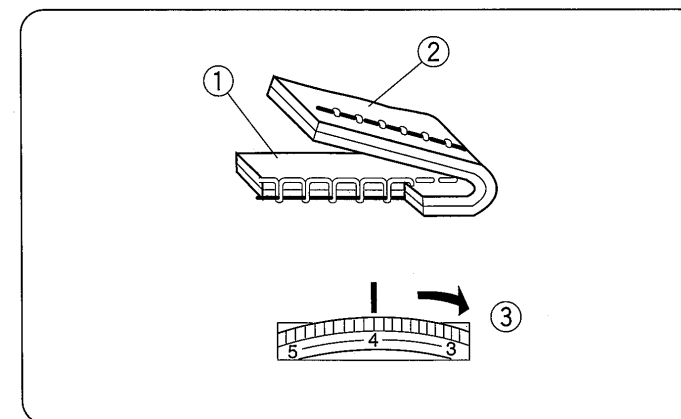

• Tension is too loose

The top thread shows through on the wrong side of the fabric and it will feel bumpy. Turn the dial to the right to tighten the top thread tension.

- ① Right side of fabric
- ② Wrong side of fabric
- ③ To tighten

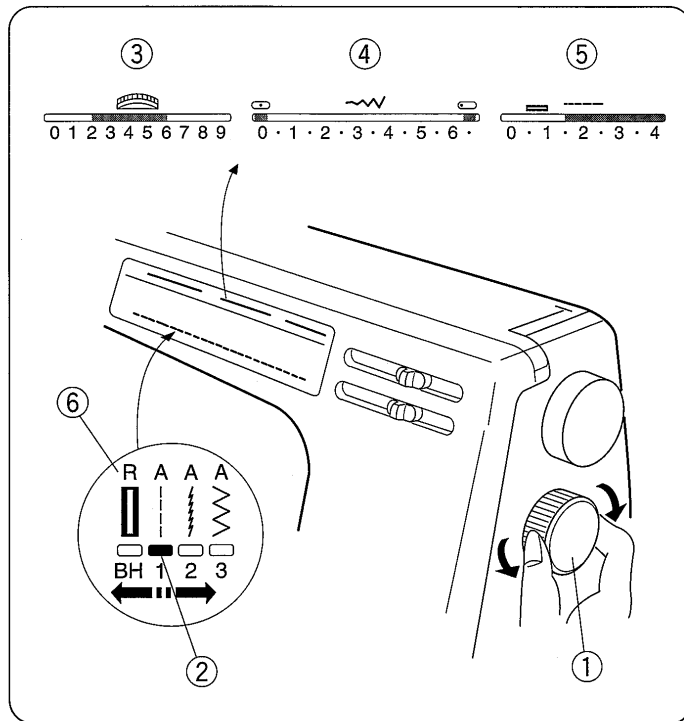

Pattern Selector Dial

Raise the needle and turn the pattern selector dial until the red indication is below the desired stitch.

At the same time the appropriate thread tension, zigzag width and stitch length are indicated in the upper portion of the guide message window.

- ① Pattern selector dial
- ② Red indicator mark
- ③ Thread tension dial
- ④ Stitch width
- ⑤ Stitch length
- ⑥ Symbol mark for presser foot (Recommended presser foot)

* Concerning items ③ through ⑥ above, there sometimes is a discrepancy between the settings shown on the front panel and those shown on the reference chart inside the top cover.

The reference chart settings are recommended for the special sewing techniques illustrated on the chart.

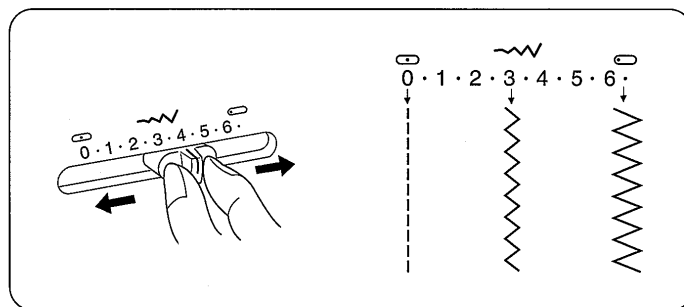

Zigzag Width Control

The higher the number, the wider the stitch width. This machine will sew the maximum 6.5 mm (0.25") wide zigzag.

* Raise the needle above the fabric when you set the stitch width.

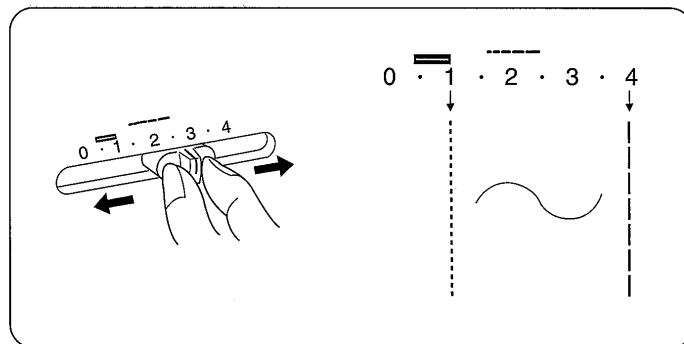

Stitch Length Control

The higher the number, the longer the stitch length. You can select the suitable stitch length for fabrics that you plan to sew.

Note:

Stitch length is automatically set for stretch stitch patterns on pattern number 2, 11 to 18.

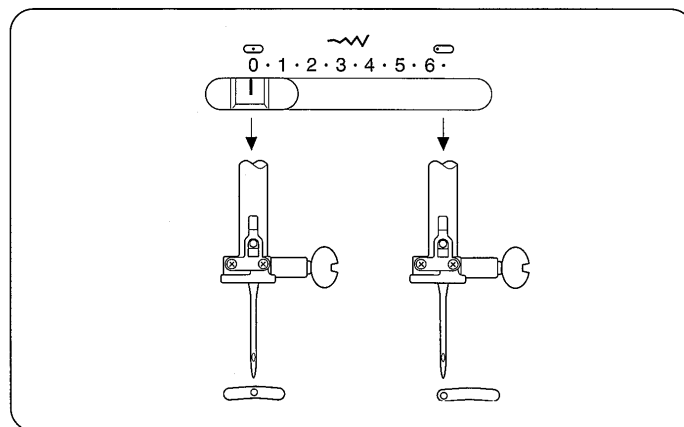

Infinite Needle Position

When pattern number 1 is selected and the stitch width control is activated, you can move the needle between center and left needle positions.

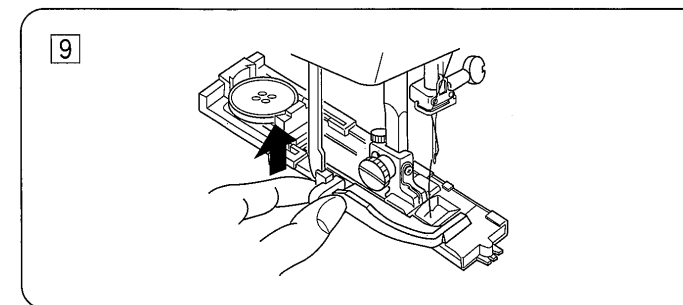

⑨ When finished, push the buttonhole lever up as far as it will go.

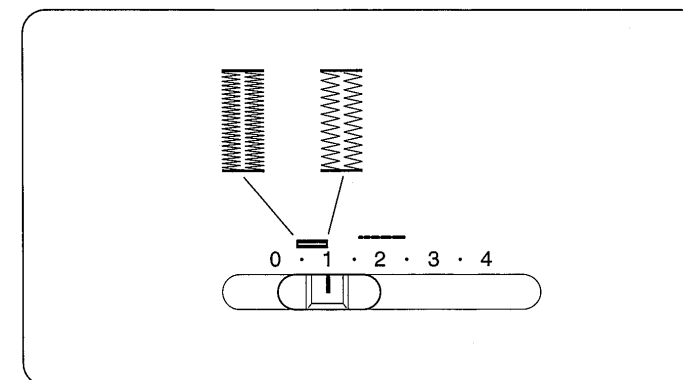

• To adjust buttonhole stitch density.

Set the stitch length slider between 0.5 and 1.0 to adjust the buttonhole stitch density.

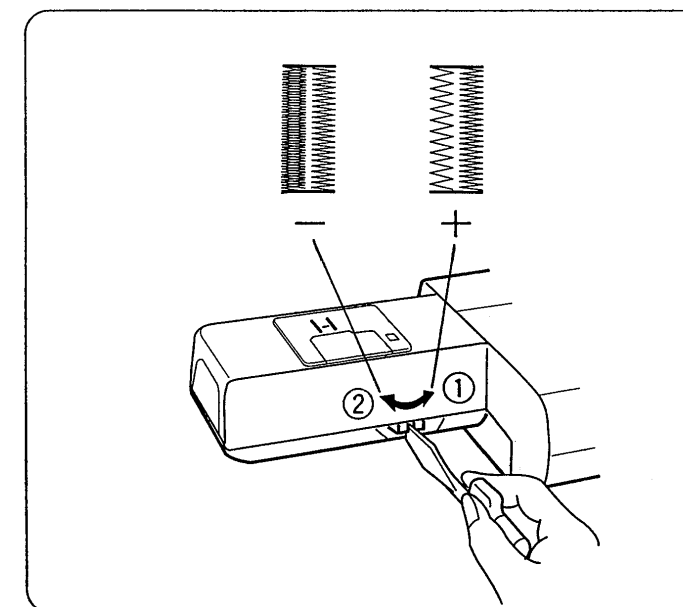

If the stitch density on the left and right side of the buttonhole are unbalanced, remove the accessory box and adjust the pitch balance dial.

- ① If the left side is denser than right side, turn the adjusting dial with the screw driver in the "+" direction.
- ② If the left side is less dense than the right side, turn the adjusting dial with the screw driver in the "-" direction.

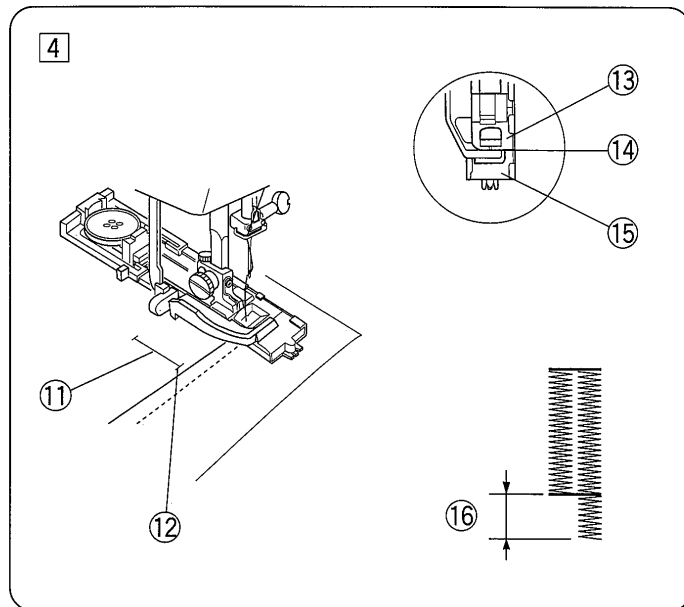

4 Draw both threads to the left under the foot. Insert the garment under the foot, and lower the needle at the starting point.

Then lower the automatic buttonhole foot.

* Make sure there is no gap ⑭ between the slider ⑬ and the spring holder ⑮.

If there is a gap ⑭, the length of the rows will be different, as shown in ⑯.

- ① Mark for placement of buttonhole
- ② Starting point
- ③ Slider
- ④ There should be no gap.
- ⑤ Spring holder
- ⑥ Difference

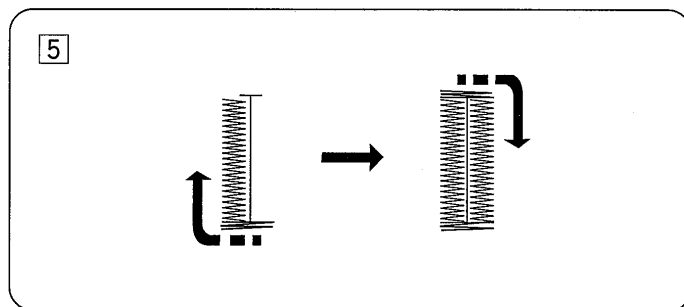

5 Sew slowly and stop the machine at the starting point when a buttonhole is completed.

* The front bartack and left row first, then the back bartack and right row.

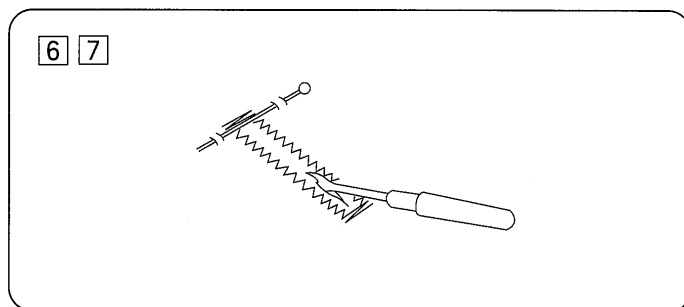

6 Cut both needle and bobbin threads leaving about 10 cm (4") thread ends. Draw the needle thread to the wrong side of the fabric by pulling the bobbin thread. Then, knot the threads.

7 Insert a pin inside the bartack. Then cut the opening with a seam ripper. Take care not to cut the stitches.

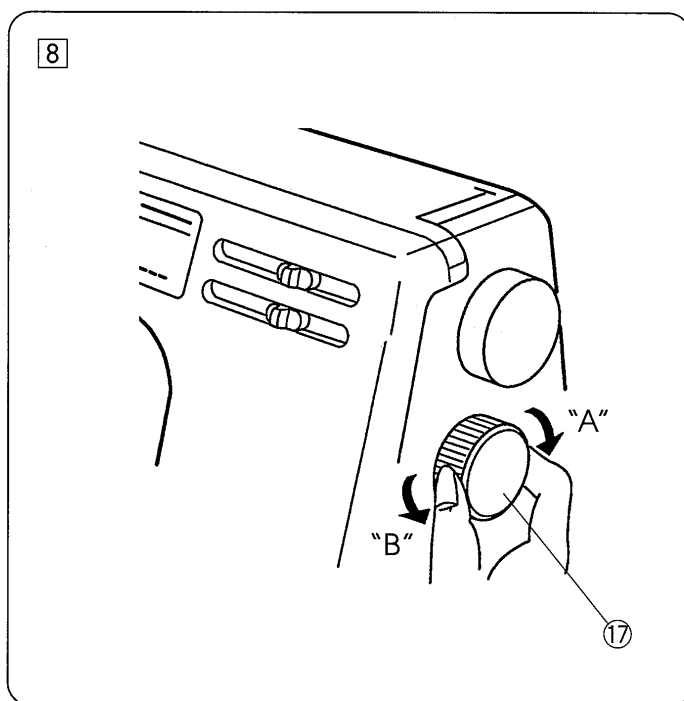

(To continue buttonhole sewing)

8 To reset the buttonhole sewing function, select a different stitch pattern with the pattern selector dial "A", then return it to the buttonhole.

3 ⑰ Pattern selector dial

Straight Stitching

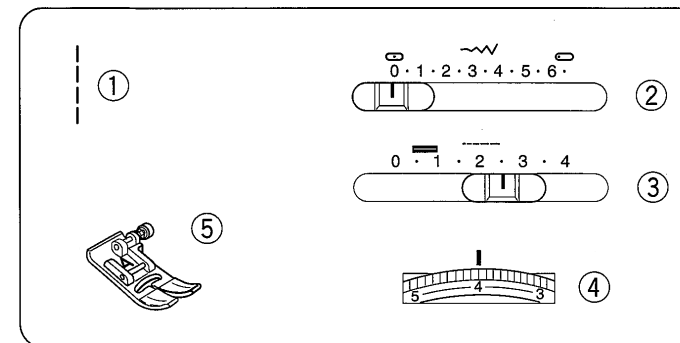

- ① Stitch selector: 1
- ② Stitch width: () ()
- ③ Stitch length: 1.5-4
- ④ Top thread tension: 2-6
- ⑤ Presser foot: A: Zigzag foot

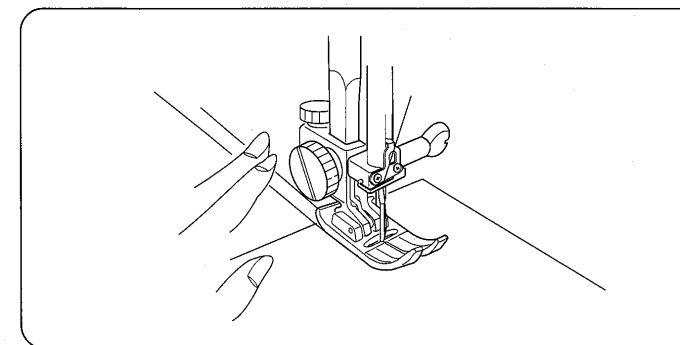

• Starting to Sew

Raise the presser foot and position the fabric next to a seam guide line on the needle plate (see page 18).

Lower the needle to the point where you want to start.

Lower the presser foot and pull the threads toward the back. Depress the foot control.

Gently guide the fabric along the seam guide line letting the fabric feed naturally.

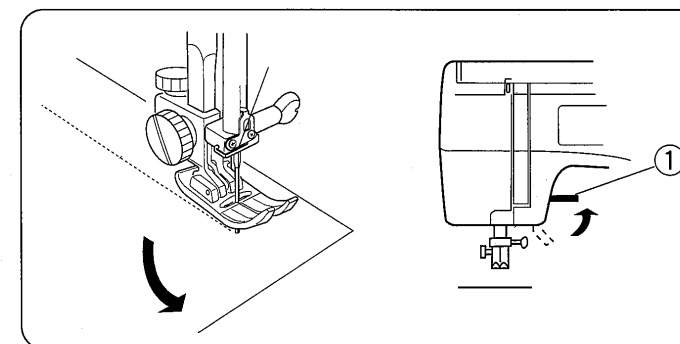

• Changing Sewing Direction

Stop the machine and turn the handwheel toward you to bring the needle down into the fabric.

Raise the presser foot.

Pivot the fabric around the needle to change sewing direction as desired. Lower the presser foot.

① Presser foot lifter

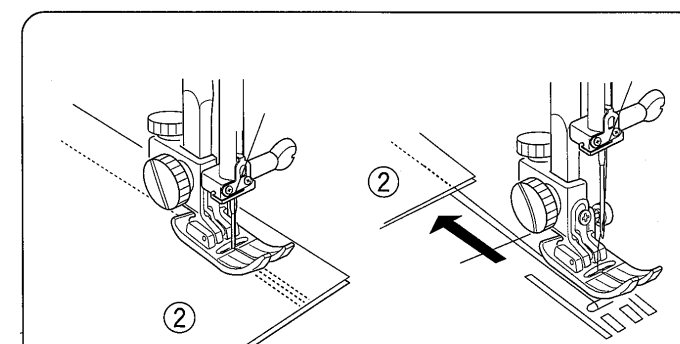

• Finishing Sewing

To fasten the ends of seams, press the reverse button and sew several reverse stitches.

Raise the presser foot. Remove the fabric, draw the threads to the back and cut using the thread cutter.

The threads are cut the proper length for starting the next seam.

- ① Thread cutter
- ② Fabric

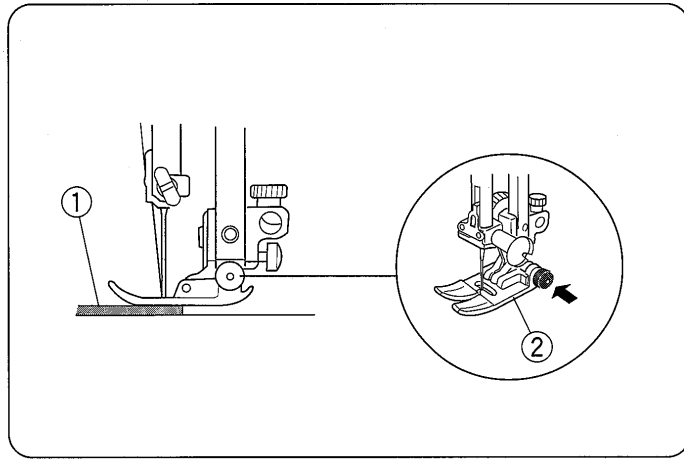

Sewing on Heavy Fabrics

Pressing the black button on Foot A (before lowering) locks it in a horizontal position. This ensures even feeding at the beginning of seams and helps when sewing many layers of fabric.

When you reach a point of increased thickness, lower the needle and raise the foot. Press in the black button, then lower the foot and continue sewing.

It releases automatically after a few stitches.

- ① Fabric
- ② A: Zigzag foot

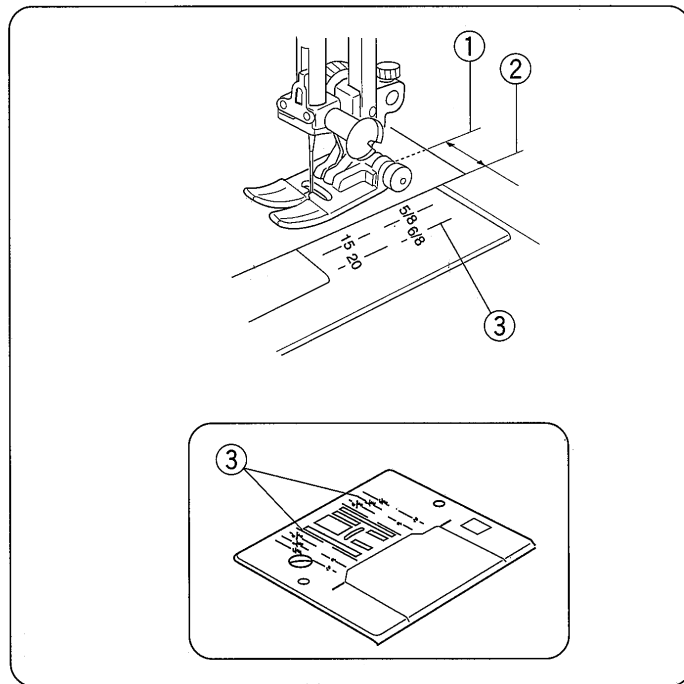

Seam Allowance Lines

The seam guides on the needle plate and hook cover plate help you measure seam width.

* The number indicates the distance between the middle needle position (•) and the seam allowance line.

	Millimeters		Inches		
Marks on needle plate	15	20	4/8"	5/8"	6/8"

- ① Middle needle position
- ② Edge of fabric
- ③ Needle plate guide lines

Turn a Square Corner

To turn a square corner 1.6 cm (5/8") from the fabric edge.

1. Stop stitching and lower the needle by turning handwheel counterclockwise when the fabric edge facing you lines up with the cornering guide as shown.
2. Raise the presser foot and turn the fabric to line the edge with the 1.6 cm (5/8") seam guide.
3. Lower the presser foot and begin stitching in the new direction.

- ① Cornering guide
- ② Presser foot lifter

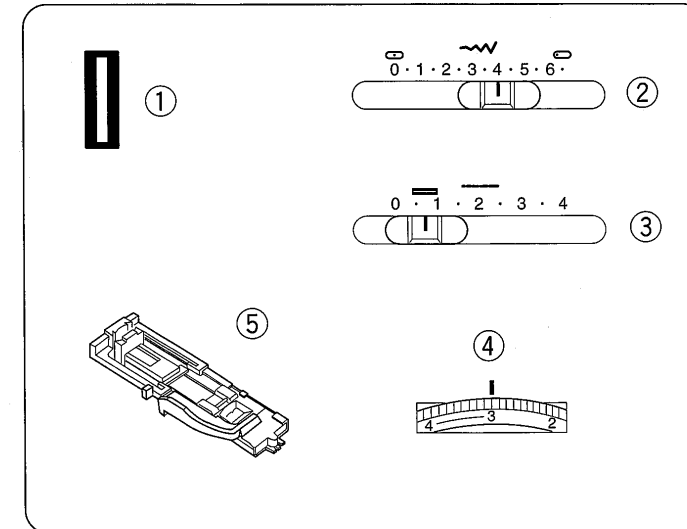
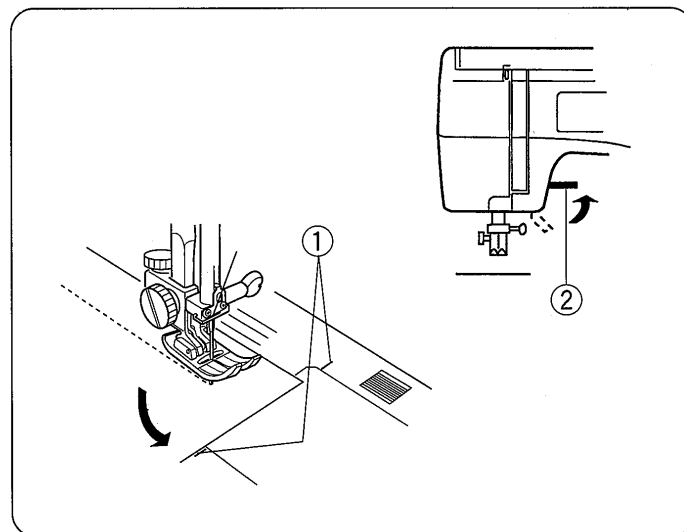

Automatic Buttonhole

- ① Stitch selector: BH
- ② Stitch width: 4-6.5
- ③ Stitch length: [thick bar]
- ④ Top thread tension: 1-5
- ⑤ Presser foot: R: Automatic button hole foot

- * The size of buttonhole is automatically set by placing the button in the automatic buttonhole foot (R).
- * The button holder of the foot takes a button size up to 2.5 cm (1") in diameter.
- * Make a test buttonhole on a sample duplicating the fabric, interfacing and seams of the actual garment.
- * Place the button on the fabric sample and mark the top and bottom to determine the position of buttonhole.
- * Use interfacing on the stretch fabrics.

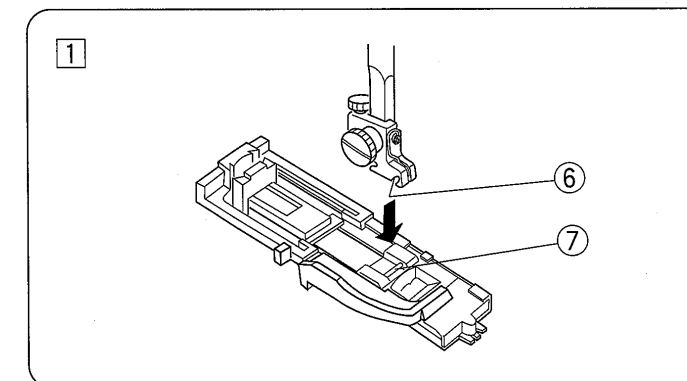

- 1 Attach the automatic buttonhole foot R. Make sure the groove on the holder catches the pin on the foot when lowering the presser foot.

- ⑥ Groove
- ⑦ Pin

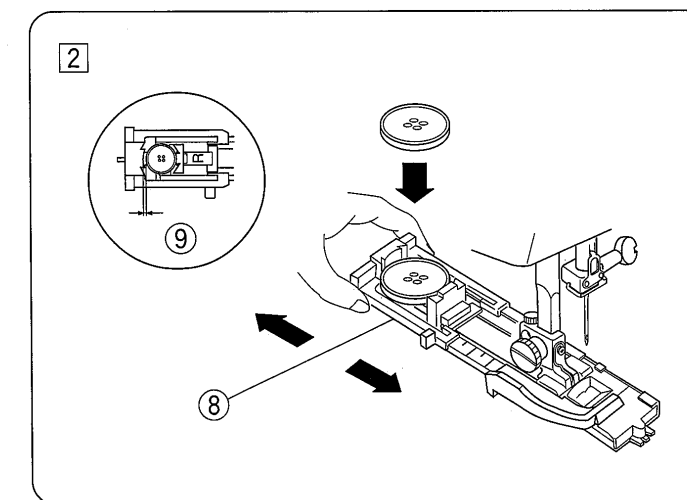

- 2 Pull the button holder to the back, and place the button in it. Push it together tightly on the button.

- ⑧ Button holder

If the button is extremely thick, make a test buttonhole. If it is difficult to fit the button through the test buttonhole, lengthen by pulling the button holder on the foot back to increase length.

- ⑨ Gap

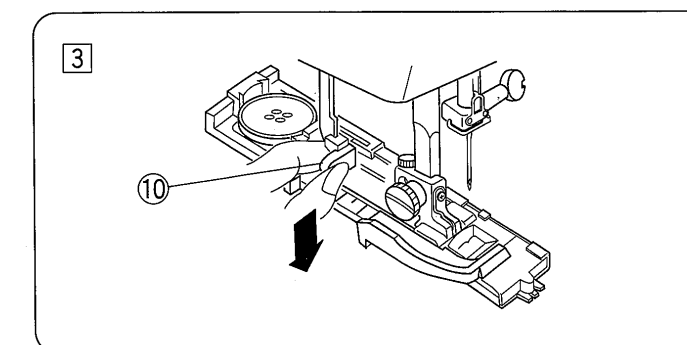

- 3 Pull the buttonhole lever downward as far as it will go.

- ⑩ Buttonhole lever

Sewing Buttons

- ① Stitch selector: 3
- ② Stitch width: 3-3.5
- ③ Top thread tension: 3-7
- ④ Drop feed dog
- ⑤ Presser foot: F: Satin stitch foot

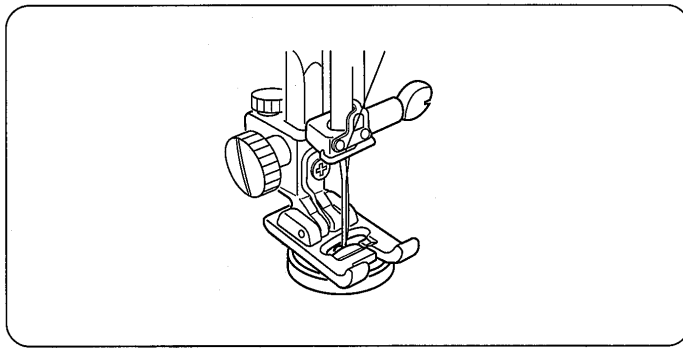
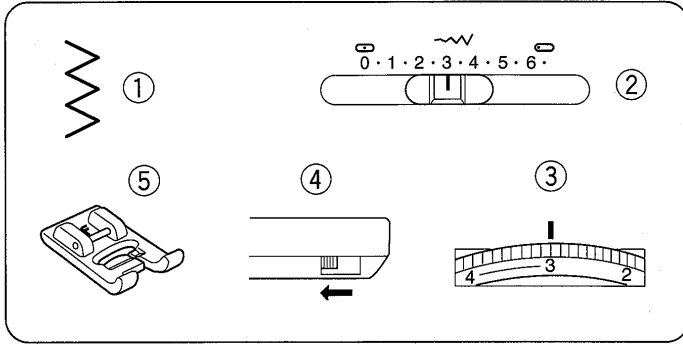

Tape the button over the placement mark. A pin can be placed on top of the foot to form a shank. Before lowering the foot, test the needle swing, making sure the needle drops in each hole. Adjust the stitch width if necessary and lower the foot. Align both holes of button with the needle swing, lower the foot and depress the foot control.

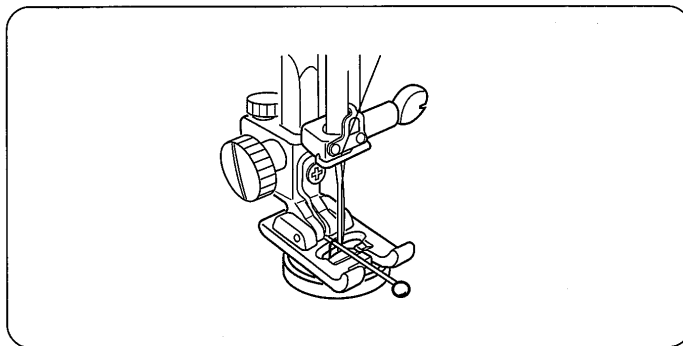

Sew about 10 stitches, then pull out approximately 20 cm (8") of both the needle and bobbin thread and cut.

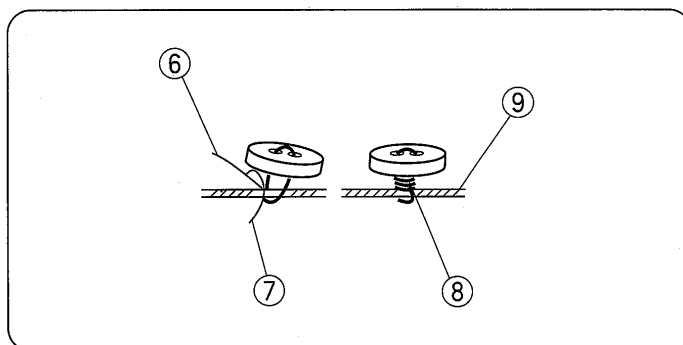

Pull the needle thread down through the hole in the button (so it is between the hole and fabric). Now, pull the needle thread firmly to draw the bobbin thread up through the fabric. Wind one thread clockwise around the shank, the other counterclockwise. Finally, tie the 2 threads together.

- ⑥ Needle thread
- ⑦ Bobbin thread
- ⑧ Shank
- ⑨ Fabric

Zigzag Stitching

- ① Stitch selector: 3
- ② Stitch width: 1-6.5
- ③ Stitch length: 0.5-3
- ④ Top thread tension: 3-5
- ⑤ Presser foot: A: Zigzag foot

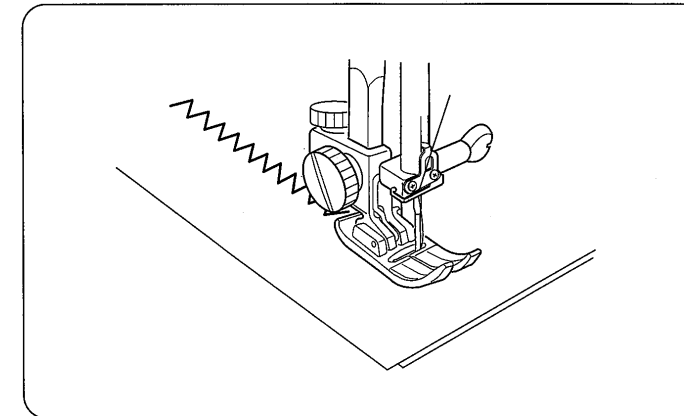
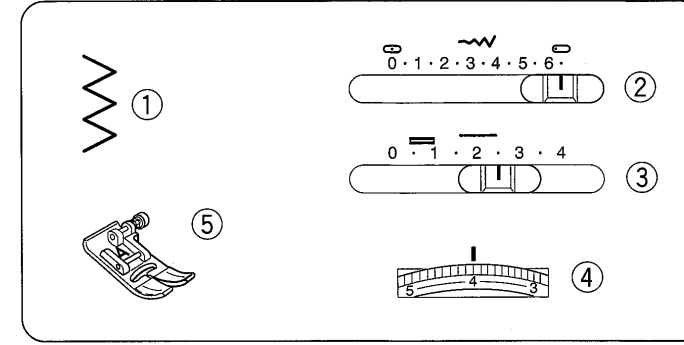

Simple zigzag stitching is widely used for overcasting, appliquéing, sewing on buttons, etc.

Overcasting

- ① Stitch selector: 3
- ② Stitch width: 5
- ③ Stitch length: 1-2
- ④ Top thread tension: 3-7
- ⑤ Presser foot: C: Overedge foot

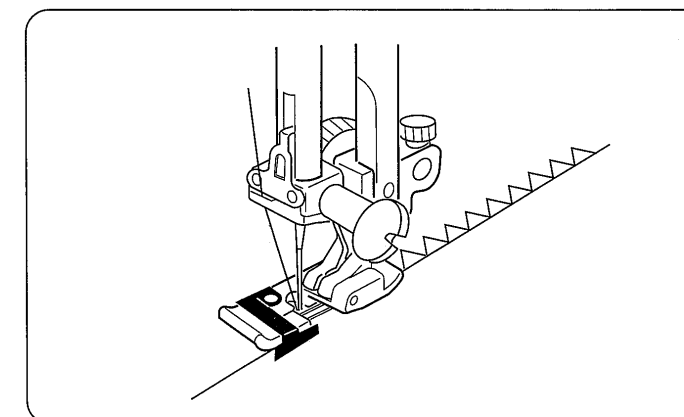
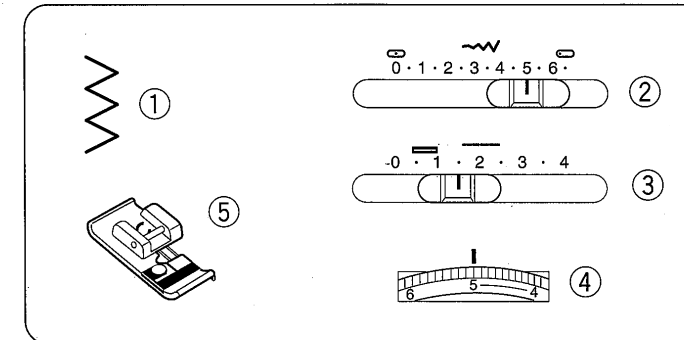

This type of stitch is used on the seam allowance to prevent fabrics from fraying at raw edges. It can be used to finish a hem edge. Place the edge of the fabric next to the black prong of foot C.

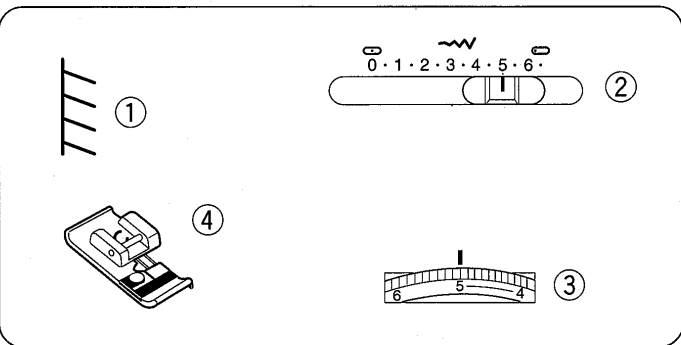

Overedge Stitch

- ① Stitch selector: 15
- ② Stitch width: 5
- ③ Top thread tension: 3-7
- ④ Presser foot: C: Overedge foot

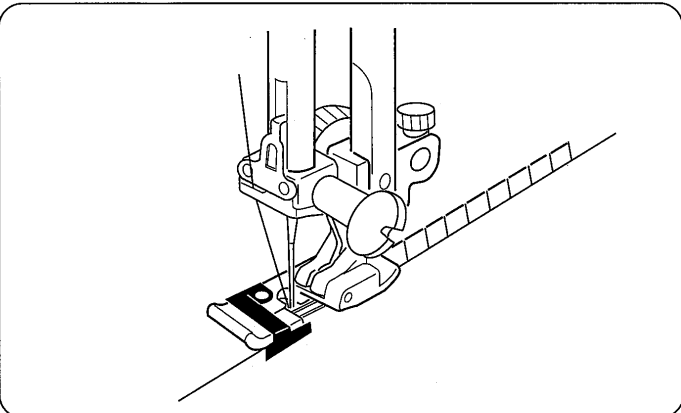

Place the edge of the fabric next to the black prong on the foot.
 The wires on this foot prevent light weight fabric from rolling and creating a ridge. The black prong guides your sewing so the needle falls off the fabric wrapping the threads around the edge to stop raveling.

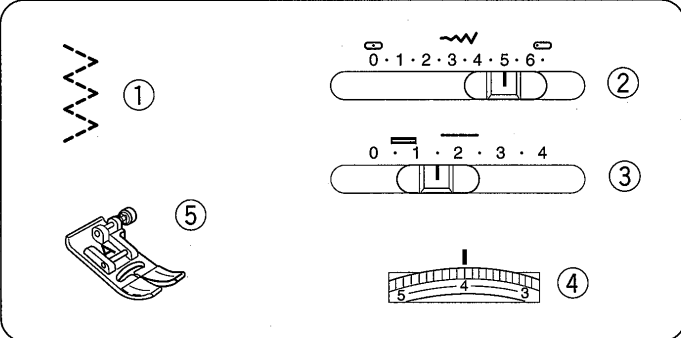

Tricot Stitch

- ① Stitch selector: 5
- ② Stitch width: 3-6.5
- ③ Stitch length: 0.5-1.5
- ④ Top thread tension: 3-6
- ⑤ Presser foot: A: Zigzag foot

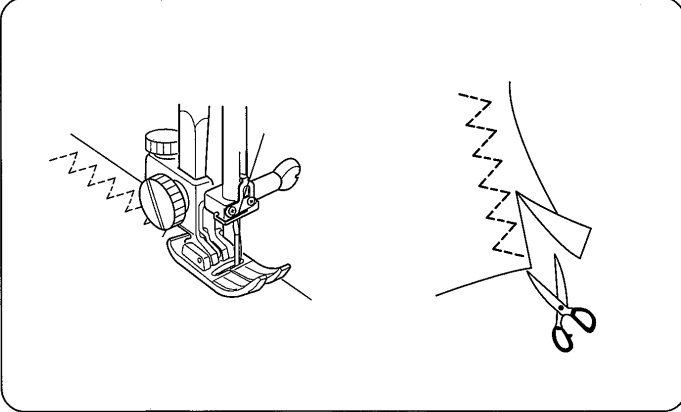

This stitch is used to finish the seam allowance on synthetics and other fabrics that tend to pucker. The stitch is excellent for darning and mending tears.
 Place your fabric to allow a 1.5 (5/8") seam.
 Trim the seam allowance after sewing.

Note: Be careful not to cut the stitches.

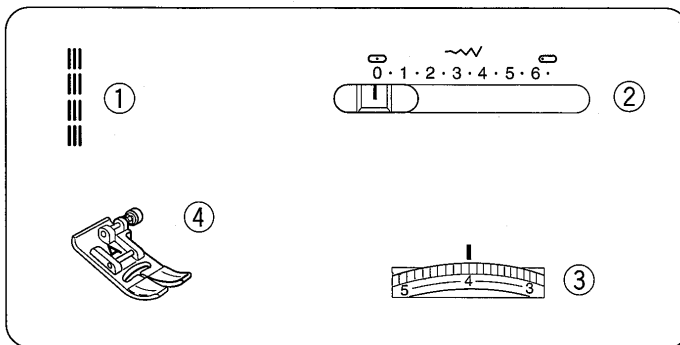

Triple Strength Stitch

- ① Stitch selector: 18
- ② Stitch width: ()
- ③ Top thread tension: 2-6
- ④ Presser foot: A: Zigzag foot

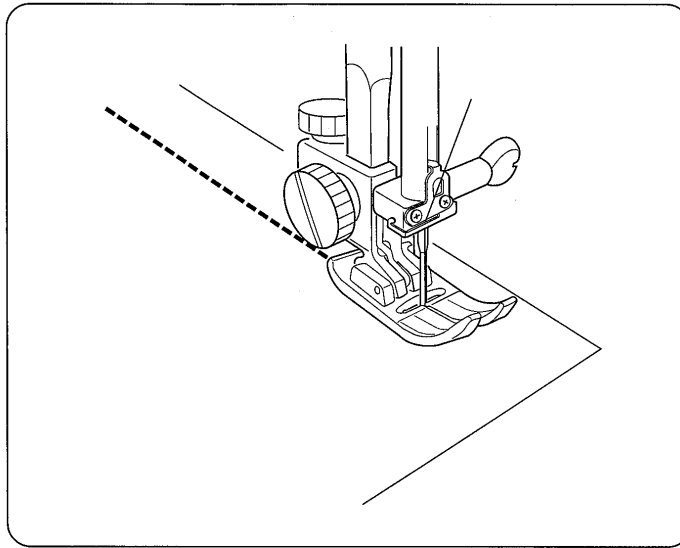

This strong, durable stitch is recommended where both elasticity and strength are needed to insure comfort and durability.
 Use it to reinforce areas such as crotch and armhole seams.
 Also use when constructing items such as backpacks for extra strength.
 The stitch is sewn with two stitches forward and one stitch backward, forming a seam that does not rip easily.
 Garments should be basted for fitting before seaming.

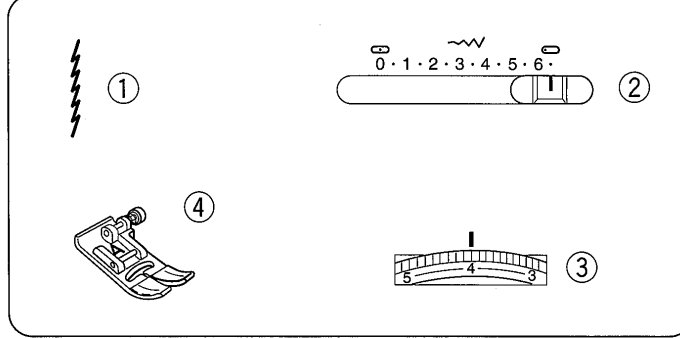

Outline Stretch Stitch

- ① Stitch selector: 2
- ② Stitch width: ()
- ③ Top thread tension: 3-6
- ④ Presser foot: A: Zigzag foot

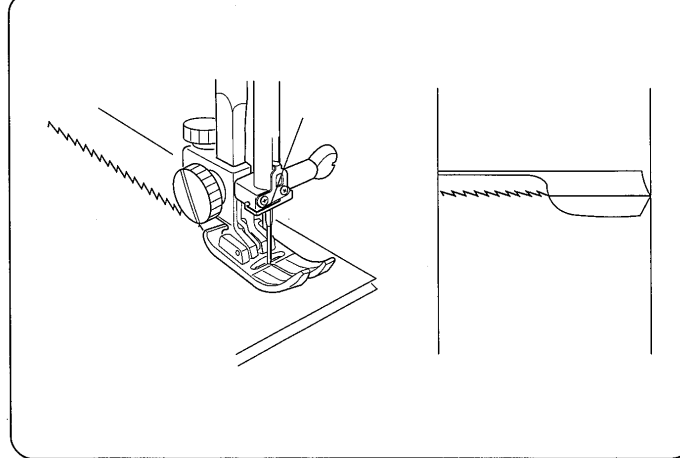

Pattern is a narrow stretch stitch designed to eliminate puckering on knit fabrics and bias seams, while permitting the seam to be pressed completely flat.
 For a 1.5 cm (5/8") seams, use the 2 cm (6/8") marking on the needle plate.
 When sewing light weight fabrics, set the pressure dial at 1 or 2.